

REVISION HISTORY			
REV	DATE	BY	DESCRIPTION
B	11SEP2015	BDT/DJK	PRN: P2015-0987

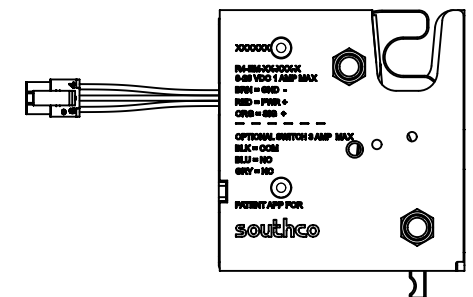

WITH CONNECTOR  
R4-EM-R21-131  
R4-EM-R22-131  
R4-EM-R23-131

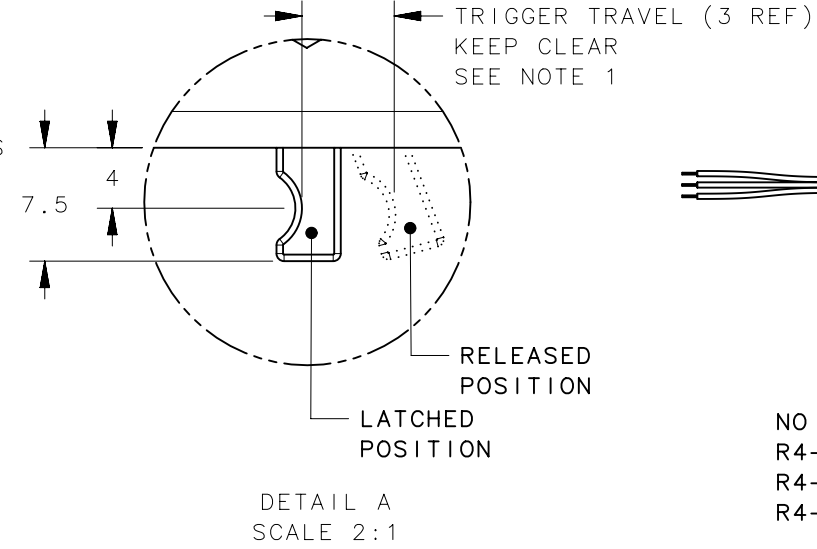
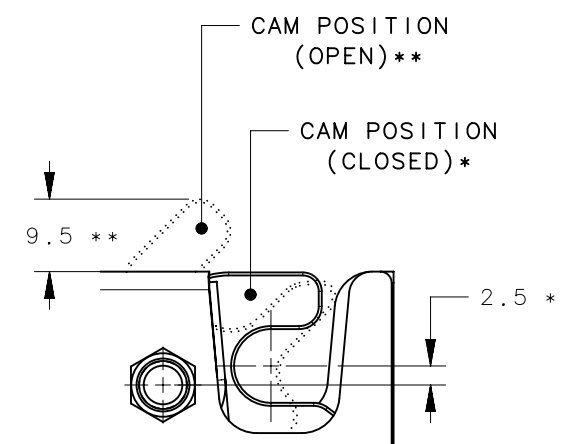
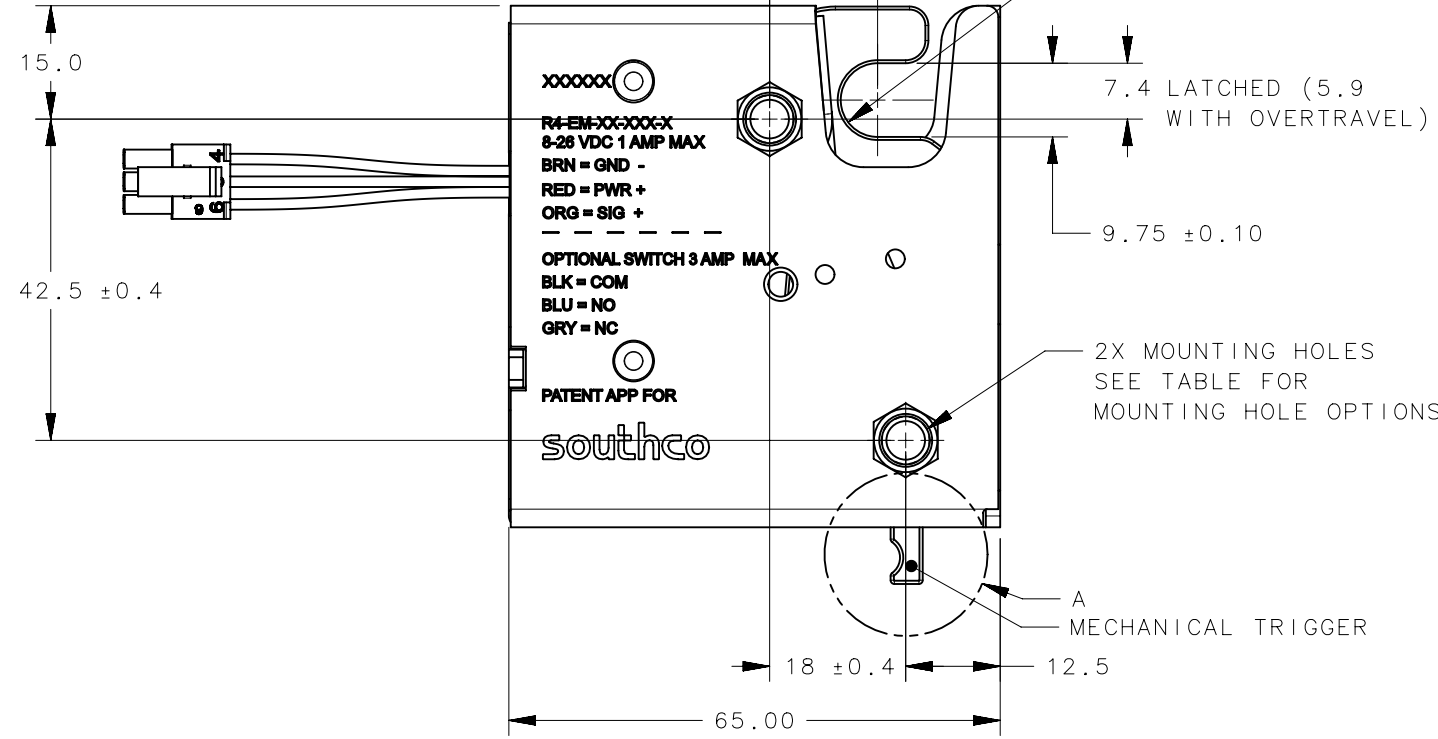
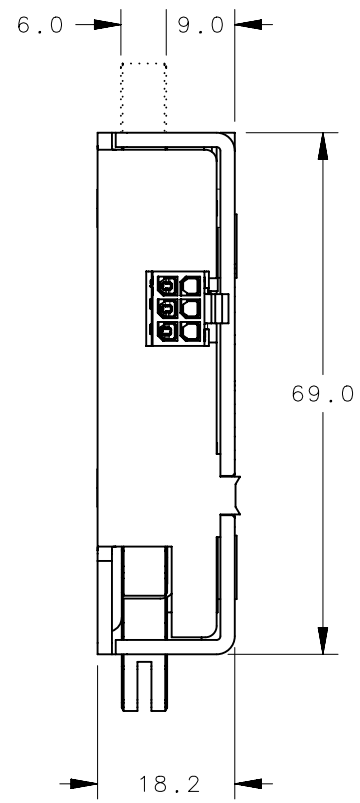
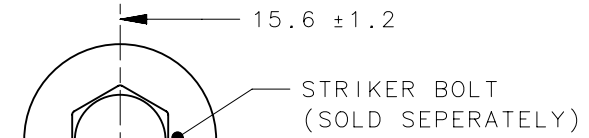
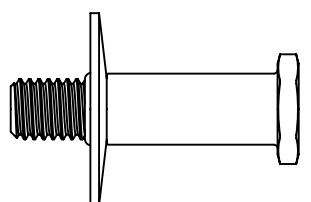
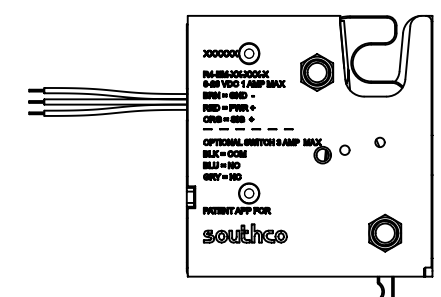

NO CONNECTOR  
R4-EM-R21-132  
R4-EM-R22-132  
R4-EM-R23-132

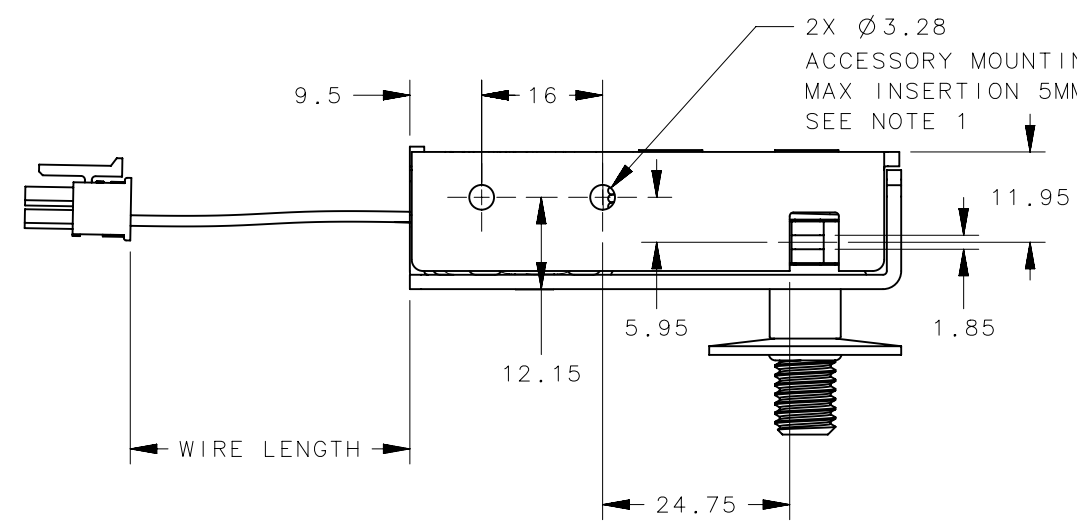

LATCH PART NUMBERS				
ASSEMBLY PART NUMBER	MOUNTING HOLE OPTION	WIRE LENGTH	CONNECTOR	SWITCH
R4-EM-R21-131	1/4-20 UNC THREAD	150MM	YES	NO
R4-EM-R22-131	M6 x 1 THREAD			
R4-EM-R23-131	Ø 7.0 THRU HOLE			
R4-EM-R21-132	1/4-20 UNC THREAD	425MM	NO	
R4-EM-R22-132	M6 x 1 THREAD			
R4-EM-R23-132	Ø 7.0 THRU HOLE			

THIRD ANGLE PROJECTION	 CONNECT • CREATE • INNOVATE			
			MILLIMETERS [IN]	
			TOLERANCES UNLESS OTHERWISE NOTED	
ALL DIMENSIONS WITHOUT TOLERANCES ARE FOR REFERENCE ONLY.		DESCRIPTION R4-EM ROTARY, REAR TRIGGER, TIME DELAYED RE-LOCK		
PROPRIETARY ITEM EXCEPT FOR USES EXPRESSLY GRANTED IN WRITING, INFORMATION DISCLOSED HEREON IS CONFIDENTIAL AND ALL RIGHTS, PATENT AND OTHERWISE, ARE RESERVED BY SOUTHCO, INC.	SIZE B	SYSTEM NX	DWG NO. J-R4-EM-R21-131	
PER ASME Y14.5M-1994	DRAWN BY BGL/CLB	DATE 16OCT2012	SCALE 1:1	
			SHEET 1 OF 2	

REVISION HISTORY			
REV	DATE	BY	DESCRIPTION
B	11SEP2015	BDT/DJK	PRN: P2015-0987

NOTE:

A. MATERIAL AND FINISH:

HOUSING, CAM, TRIGGER AND PINS: STEEL ZINC PLATED  
ELECTRONIC ACTUATOR: PLASTIC AND ACETALS AND METAL COMPONENTS.

B. ELECTRICAL SPECIFICATION:

OPERATING VOLTAGE: 8 TO 26 VDC  
TYPICAL OPERATING CURRENT: LESS THAN 500 mA AT 12VDC  
PEAK/STALL OPERATING CURRENT: 1A MAX AT 12VDC STALL LIMITED TO 1.4 SECONDS  
STANDBY CURRENT LESS THAN 185 MICROAMP  
CONTROL SIGNAL HIGH (UNLOCK COMMAND): 6 TO 26VDC, 25 mA MAX  
CONTROL SIGNAL LOW (LOCK COMMAND): 0 TO 1VDC (OPEN)  
LATCH TRANSIT TIME TO RELEASE: 600 MILLISECONDS NO LOAD, 1 SECOND MAX.  
OPERATING TEMPERATURE RANGE 20C TO 60C

C. ELECTRICAL CONNECTIONS AND HOOKUP:

A BASIC SWITCH CONTROL ELECTRICAL HOOKUP DIAGRAM IS PROVIDED FOR REFERENCE. CONSULT WITH A SOUTHCO REPRESENTATIVE FOR ADDITIONAL ELECTRICAL HOOKUP INFORMATION.  
-CONNECT POWER, GROUND AND CONTROL SIGNAL WIRES TO AN APPROPRIATE DC POWER SUPPLY.  
-A DC POWER SUPPLY CAPABLE OF SUPPLYING 1 AMP MINIMUM IS RECOMMENDED.  
-POWER MUST BE AVAILABLE TO OPERATE THE LATCH AND MUST REMAIN AVAILABLE DURING THE FULL TRANSIT TIME OF THE LATCH DURING LOCKING OR UNLOCKING.

**CAUTION!** LATCH CAN BE DAMAGED IF WIRED INCORRECTLY, OR IF IMPROPER VOLTAGE IS APPLIED!

WIRE COLOR CODE/CONNECTOR PIN ASSIGNMENT  
PIN1: BROWN: GROUND (-)  
PIN2: RED: POWER (-12v TYPICAL)  
PIN3: ORANGE: CONTROL SIGNAL (+12V TYPICAL)

D. ELECTRICAL OPERATION:

TO UNLOCK OR RELEASE THE LATCH:  
-PROVIDE THE FOLLOWING CONTROL SIGNAL TO THE ORANGE WIRE OR CONNECTOR PIN 3  
-PROVIDE 6 TO 26VDC (CONTROL SIGNAL HIGH) FOR A MINIMUM OF 50 MILLISECONDS  
-THE CONTROL SIGNAL CAN REMAIN HIGH INDEFINITELY  
-THE LATCH WILL STAY UNLOCKED FOR A MINIMUM OF 1 SECOND OR AS LONG AS THE SIGNAL IS HIGH  
TO LOCK THE LATCH:  
-PROVIDE THE FOLLOWING CONTROL SIGNAL TO THE ORANGE WIRE OR CONNECTOR PIN 3  
-PROVIDE 0 TO 1VDC (CONTROL SIGNAL LOW). POWER MUST BE AVAILABLE DURING TRANSIT TO LOCKED POSITION

NOTE:

-THE DOOR IS NOT LATCHED WHEN IN THE UNLOCKED POSITION. ENSURE THAT YOUR DOOR IS BIASED CLOSED OR DETENTED IN THE CLOSED POSITION. THE CAM MUST REMAIN IN THE CLOSED POSITION TO RE-LOCK  
-FROM THE LOCKED POSITION WITH THE CAM IN THE OPEN POSITION THE DOOR CAN BE PUSHED TO CLOSE AND WILL LOCK

E. OPTIONAL LATCH CONNECTOR:

MANUFACTURER: MOLEX, SERIES MICROFIT 3.0  
-CONNECTOR RECEPTICAL 6 POSITION 3MM VERTICAL DUAL: MOLEX P/N: 43025-0600  
-CONTACTS: FEMALE CRIMP TERMINAL (SOCKET) MOLEX P/N: 43030-0007  
WIRE: 24 AWG STYLE 1007

WIRE LENGTH: SEE TABLE FOR AVAILABLE LENGTHS

F. MALE CONNECTOR (NOT SUPPLIED):

MANUFACTURER: MOLEX, SERIES: MICROFIT 3.0  
-CONNECTOR PLUG 6 POSITION 3MM VERTICLE DUAL MOLEX P/N: 43020-0601  
-RECOMMENDED CONTACTS (6 MAXIMUM REQUIRED): MOLEX, MALE CRIMP TERMINAL (PIN) MOLEX P/N 43031-0007  
-RECOMMENDED WIRE GAGE: 24 AWG

G. MOUNTING:

-MOUNT THE LATCH SECURELY USING TWO (2) SCREWS IN THE MOUNTING HOLES PROVIDED (SCREWS NOT PROVIDED)  
-MOUNTING HOLES ARE AVAILABLE WITH 1/4-20 UNC THREAD, M6 x 1 THREAD OR Ø7.0 THRU HOLE  
-MAXIMUM ALLOWABLE TORQUE ON THREADED MOUNTING SCREWS IS 650 N.cm (57.5 in. lbs)

H. MECHANICAL OPERATION

THE LATCH IS PROVIDED WITH A MECHANICAL TRIGGER TO RELEASE THE LATCH. THE MAXIMUM TRAVEL OF THE TRIGGER IS SHOWN IN DETAIL A. THE TRIGGER MOVES THROUGH ITS FULL TRAVEL DURING ELECTRICAL OPERATION OF THE LATCH.

**CAUTION** IT IS IMPORTANT TO NOT OBSTRUCT THE MOTION OF THE TRIGGER DURING ELECTRICAL OPERATION TO PREVENT LONGTERM DAMAGE TO THE ELECTRICAL COMPONENTS IN THE LATCH.

TWO HOLES PROVIDED CAN BE USED TO MOUNT MECHANICAL OVERRIDE LINKAGE RETAINING BRACKETS. STANDARD 1/8" BLIND RIVETS CAN BE USED FOR FASTENING. FOLLOW MAX INSERTION DEPTH INDICATED AND ENSURE THAT NO PARTICLES ENTER THE LATCH. CONTACT SOUTHCO FOR MECHANICAL RELEASE CABLES AND ACTUATORS. AN OPTIONAL KIT WITH ONE CABLE MOUNTING BRACKET AND TWO RIVETS IS AVAILABLE AS PART NUMBER R4-EM-87 SEE CUSTOMER DRAWING J-R4-EM-87 FOR MORE INFORMATION

I. STRIKER BOLT ASSEMBLY SOLD SEPARATELY

STRIKER BOLT PART NUMBER: R4-90-121-10, REFER TO CUSTOMER DRAWING J-R4-90-121 FOR ADDITIONAL INFORMATION

J. PACKAGED IN INDIVIDUAL BOXES OR ADD -1 TO PART NUMBER FOR BULK PACKAGING

EXAMPLE: R4-EM-R21-131  
R4-EM-R21-131-1

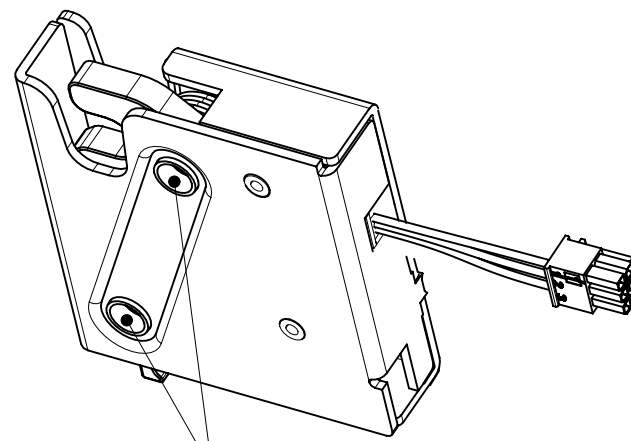

NOTE: MOUNTING HOLES ARE RECESSED 1.3 MM ON THIS SIDE



PIN 1 INDICATOR LATCH CONNECTOR

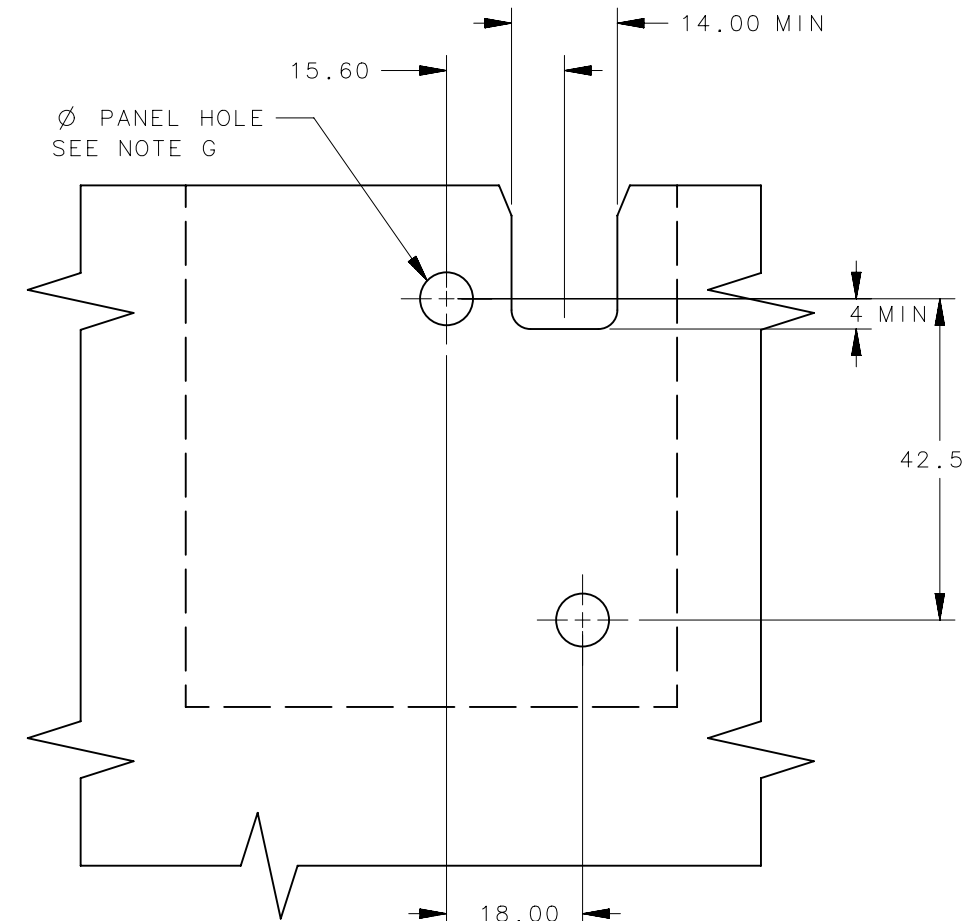
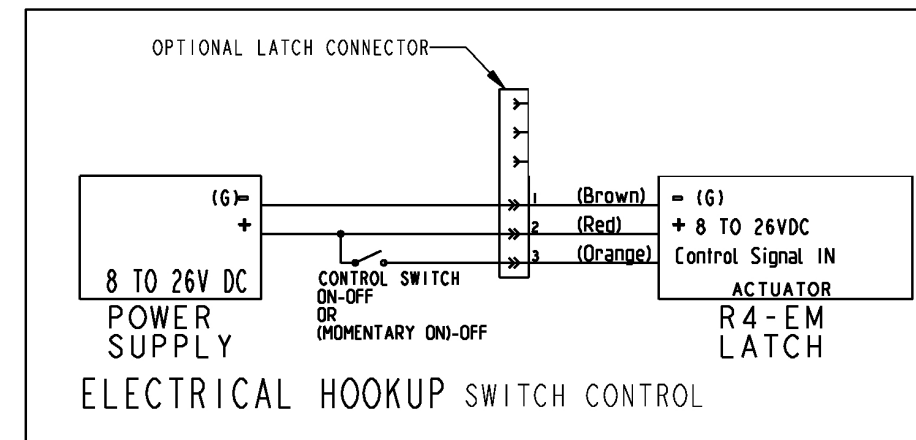

PANEL PREPARATION

THIRD ANGLE PROJECTION			<b>southco</b> <sup>®</sup> CONNECT • CREATE • INNOVATE	
TOLERANCES UNLESS OTHERWISE NOTED		DESCRIPTION R4-EM ROTARY, REAR TRIGGER, TIME DELAYED RE-LOCK		
ALL DIMENSIONS WITHOUT TOLERANCES ARE FOR REFERENCE ONLY.		SIZE B	SYSTEM NX	DWG NO. J-R4-EM-R21-131
PER ASME Y14.5M-1994		DRAWN BY BGL/CLB	DATE 16OCT2012	SCALE 1:1
PROPRIETARY ITEM EXCEPT FOR USES EXPRESSLY GRANTED IN WRITING, INFORMATION DISCLOSED HEREON IS CONFIDENTIAL AND ALL RIGHTS, PATENT AND OTHERWISE, ARE RESERVED BY SOUTHCO, INC.		SHEET 2 OF 2		