

REVISION HISTORY			
REV	DATE	BY	DESCRIPTION
H	15JAN2019	ASP/VK	PRN: P2019-0124

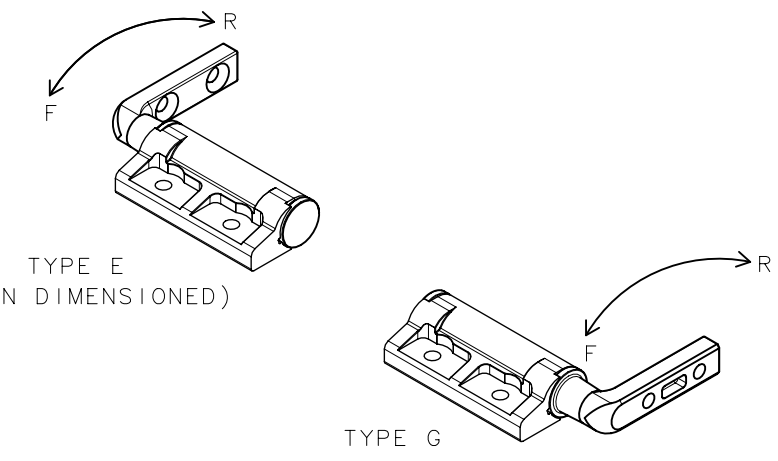

SCALE 1:2

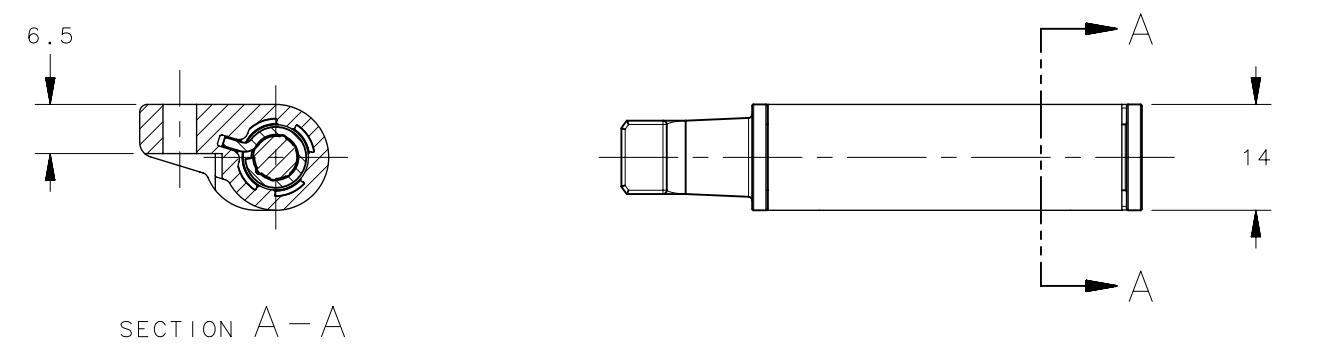
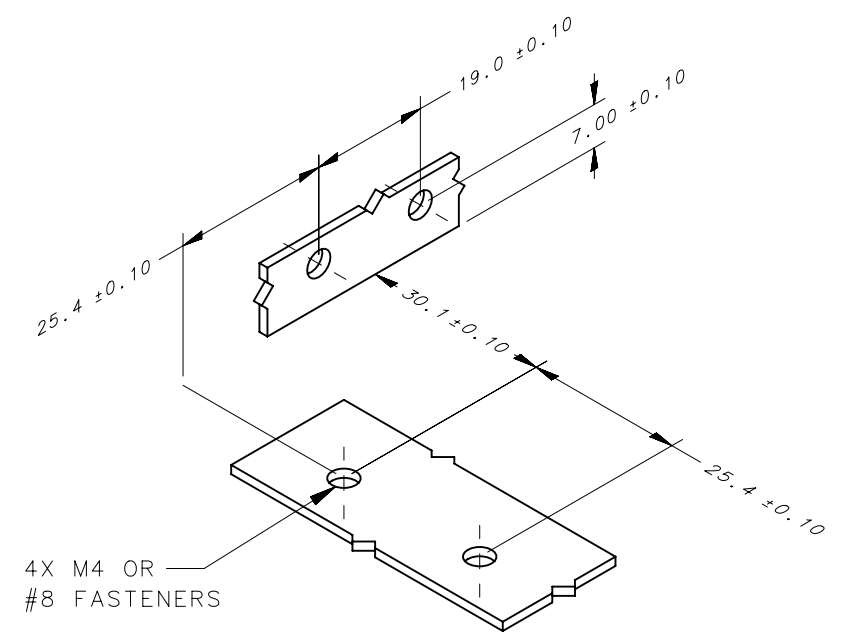
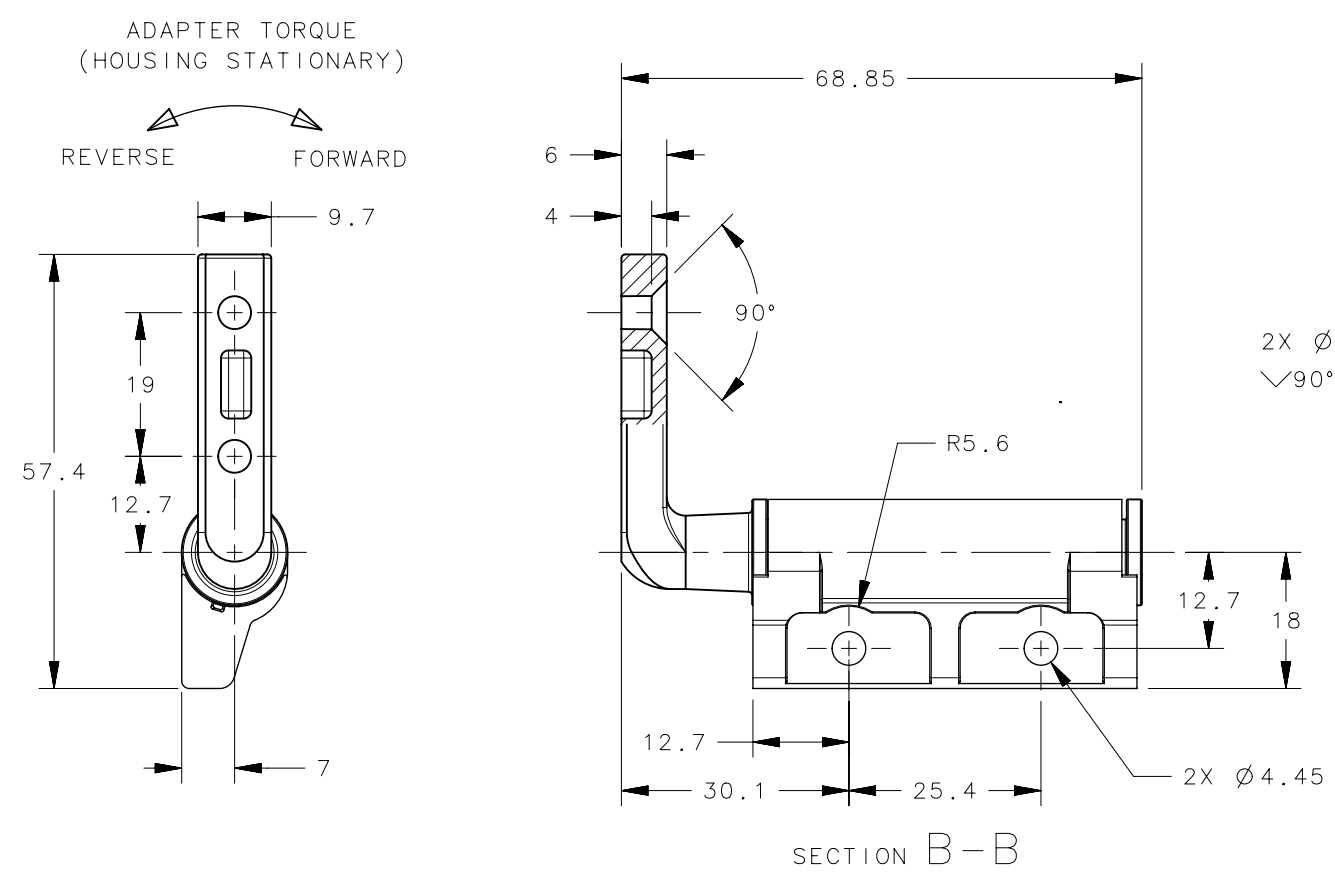

**PANEL PREPARATION
(TYPE E SHOWN DIMENSIONS)**

PART NUMBER		STATIC TORQUE	
TYPE E	TYPE G	FORWARD N*m (in-lbf)	REVERSE N*m (in-lbf)
ST-10E-120SE-XX	ST-10E-120SG-XX	1.35 (12)	1.35 (12)
ST-10E-200SE-XX	ST-10E-200SG-XX	2.26 (20)	2.26 (20)
ST-10E-280SE-XX	ST-10E-280SG-XX	3.16 (28)	3.16 (28)
ST-10E-360SE-XX	ST-10E-360SG-XX	4.06 (36)	4.06 (36)
ST-10E-200FE-XX	ST-10E-200FG-XX	2.26 (20)	2.26 (12)
ST-10E-280FE-XX	ST-10E-280FG-XX	3.16 (28)	2.26 (16.8)
ST-10E-360FE-XX	ST-10E-360FG-XX	4.06 (36)	2.44 (21.6)
ST-10E-440FE-XX	ST-10E-440FG-XX	4.97 (44)	2.93 (26)
ST-10E-200RE-XX	ST-10E-200RG-XX	1.35 (12)	2.26 (20)
ST-10E-280RE-XX	ST-10E-280RG-XX	2.26 (16.8)	3.16 (28)
ST-10E-360RE-XX	ST-10E-360RG-XX	2.44 (21.6)	4.06 (36)
ST-10E-440RE-XX	ST-10E-440RG-XX	2.93 (26)	4.97 (44)

- NOTES:
- MATERIAL AND FINISH:
HOUSING, ADAPTER AND END CAP - ZINC ALLOY
SHAFT AND TORQUE ELEMENTS - HARDENED STEEL
 - INSTALL USING M4 SCREWS
 - FOR PROPER FUNCTION, ASSEMBLY MUST INCLUDE
(1) TYPE "E" HINGE and (1) TYPE "G" HINGE
 - DIMENSIONS INDICATED AS-BUILT CONDITIONS. ADAPTER TO ADAPTER SPACING WILL SELF ADJUST DURING OPERATION.

TORQUE TOLERANCE ±20%

PART NUMBER	DESCRIPTION	FINISH
ST-10E-XXXX-33	ASSEMBLY - "AS CAST"	NATURAL
ST-10E-XXXX-50	ASSEMBLY - "PAINTED"	BLACK
ST-10E-XXXX-40	ASSEMBLY - "PAINTED"	GRAY

THIRD ANGLE PROJECTION				
MILLIMETERS [IN]				
TOLERANCES UNLESS OTHERWISE NOTED	DESCRIPTION ST-10E-E HINGE ASSEMBLY			
ALL DIMENSIONS WITHOUT TOLERANCES ARE FOR REFERENCE ONLY.	SIZE A3	SYSTEM NX	DWG NO. J-ST-10E-E	
PROPRIETARY ITEM EXCEPT FOR USES EXPRESSLY GRANTED IN WRITING, INFORMATION DISCLOSED HEREON IS CONFIDENTIAL AND ALL RIGHTS, PATENT AND OTHERWISE, ARE RESERVED BY SOUTHCO, INC.	PER ASME Y14.5M-1994	DRAWN BY GEA	DATE 28FEB2008	SCALE 1:1
			SHEET 1 OF 1	