

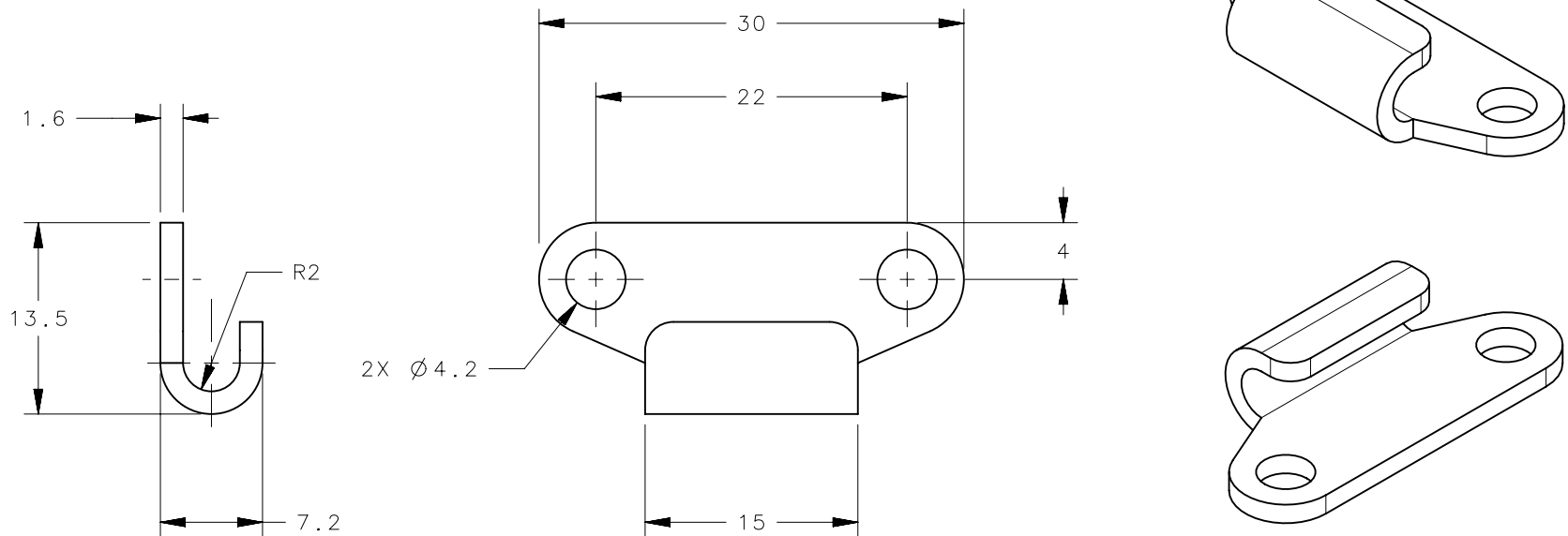

REVISION HISTORY			
REV	DATE	BY	DESCRIPTION
C	13MAY2014	TED/CMS	PRN: P2014-0911

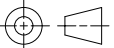

TL-17-201-52	STRIKER	STAINLESS STEEL	PASSIVATED
TL-17-201-24	STRIKER	STAINLESS STEEL	ELECTROPOLISHED
TL-17-201-13	STRIKER	STEEL	BLACK E-COAT
TL-17-201-10	STRIKER	STEEL	CHROME PLATE
TL-17-201-07	STRIKER	STEEL	ZINC PLATE, TRIVALENT CHROMATE
PART NUMBER	TYPE OF COMPONENT	MATERIAL	FINISH

THIRD ANGLE PROJECTION 		 CONNECT • CREATE • INNOVATE	
MILLIMETERS [IN]			
SURFACE AREA XXXXXmm <sup>2</sup>		DESCRIPTION TL STRIKER	
VOLUME XXXXXmm <sup>3</sup>		TOLERANCES UNLESS OTHERWISE NOTED	
PROPRIETARY ITEM EXCEPT FOR USES EXPRESSLY GRANTED IN WRITING, INFORMATION DISCLOSED HEREON IS CONFIDENTIAL AND ALL RIGHTS, PATENT AND OTHERWISE, ARE RESERVED BY SOUTHCO, INC.		ALL DIMENSIONS WITHOUT TOLERANCES ARE FOR REFERENCE ONLY.	
PER ASME Y14.5M-1994		SIZE A4	SYSTEM NX
		DWG NO. J-TL-17-201-XX	
		DRAWN BY MJW/MJW	DATE 05MAR2007
		SCALE 2:1	SHEET 1 OF 1