

REVISION HISTORY			
REV	DATE	BY	DESCRIPTION
D	27JUL2023	SDR/CRM	PRN: P2023-1395

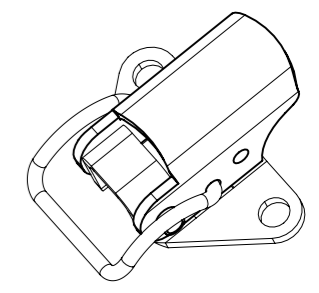

SCALE 1:1

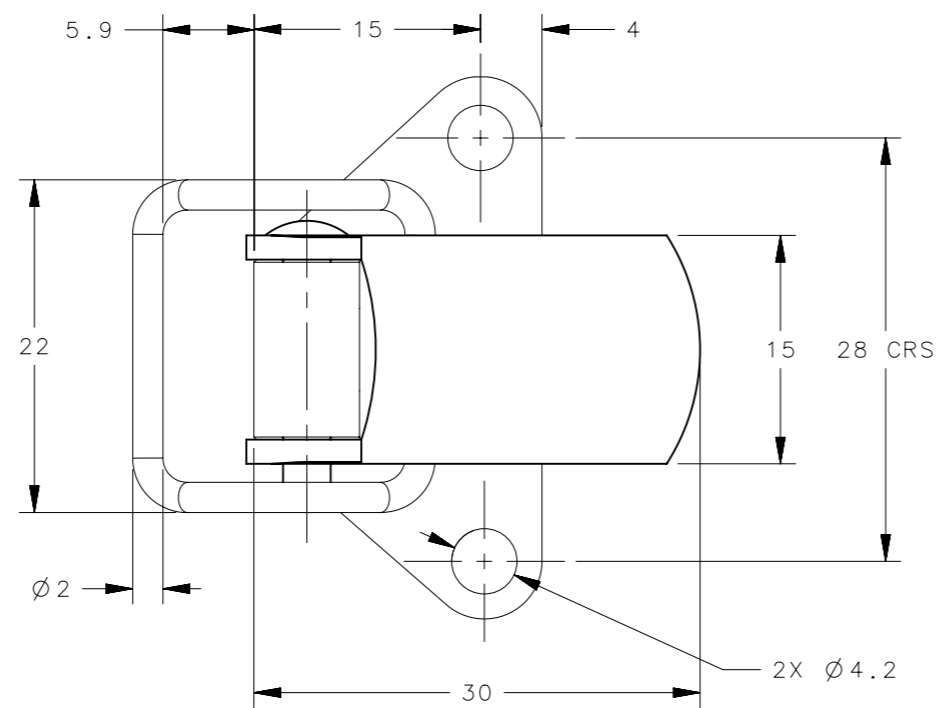
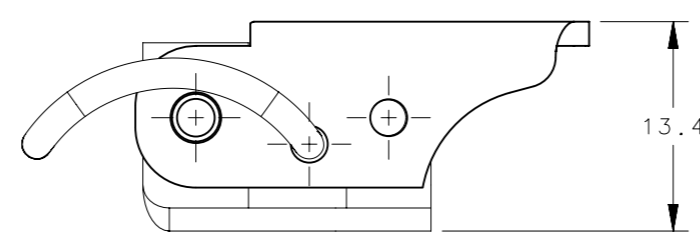

TL-20-102-53	TOGGLE LATCH ASSEMBLY	STAINLESS STEEL	BLACK OXIDE
TL-20-102-24	TOGGLE LATCH ASSEMBLY	316 STAINLESS STEEL	CLEAN
TL-20-102-52	TOGGLE LATCH ASSEMBLY	STAINLESS STEEL	CLEAN
TL-20-102-13	TOGGLE LATCH ASSEMBLY	CARBON STEEL	ZINC PLATE BLACK
TL-20-102-10	TOGGLE LATCH ASSEMBLY	CARBON STEEL	CHROME PLATE
TL-20-102-07	TOGGLE LATCH ASSEMBLY	CARBON STEEL	ZINC PLATE
PART NUMBER	TYPE OF COMPONENT	MATERIAL	FINISH

THIRD ANGLE PROJECTION			
MILLIMETERS [IN]			
TOLERANCES UNLESS OTHERWISE NOTED		DESCRIPTION TOGGLE LATCH ASSEMBLY	
ALL DIMENSIONS WITHOUT TOLERANCES ARE FOR REFERENCE ONLY.		SIZE A3	SYSTEM NX
PROPRIETARY ITEM		DWG NO. J-TL-20-102-XX	
EXCEPT FOR USES EXPRESSLY GRANTED IN WRITING, INFORMATION DISCLOSED HEREON IS CONFIDENTIAL AND ALL RIGHTS, PATENT AND OTHERWISE, ARE RESERVED BY SOUTHCO, INC.		DRAWN BY MJW	DATE 16MAY2007
PER ASME Y14.5M-1994		SCALE 2:1	SHEET 1 OF 1