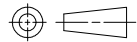

southco®

PROPRIETARY ITEM - EXCEPT FOR USES EXPRESSLY GRANTED IN WRITING INFORMATION DISCLOSED HEREON IS CONFIDENTIAL AND ALL RIGHTS PATENT AND OTHERWISE ARE RESERVED BY SOUTHCO, INC.

No. V3, MEDIUM VERSA-LATCH SERIES, DRAW LATCH

DATE	DRAWN	CHKD	SCALE	DRAWING NUMBER
13JUN03	AAB	CHW	.75:1	J-V3-0072
MILLIMETERS				 THIRD ANGLE PROJECTION

REV	DATE	DRAWN/CHKD	DESCRIPTION	PART NUMBER	MATERIAL	FINISH
A	13JUN2003	AAB/CHW	PRN: P2003-0497	V3-0072-07	SEE NOTE A	ZINC PLATE, BRIGHT
				V3-0072-69	SEE NOTE A	BLACK E-COAT

ALL DIMENSIONS WITHOUT TOLERANCES ARE FOR REFERENCE ONLY.

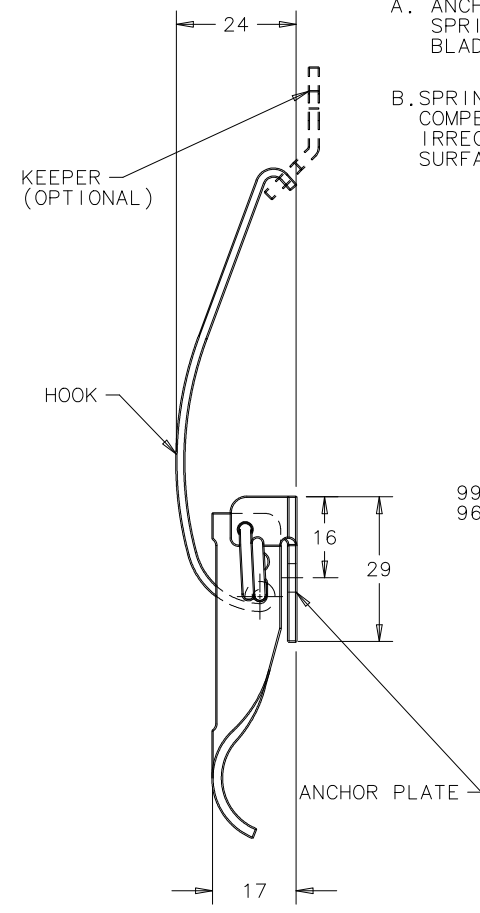
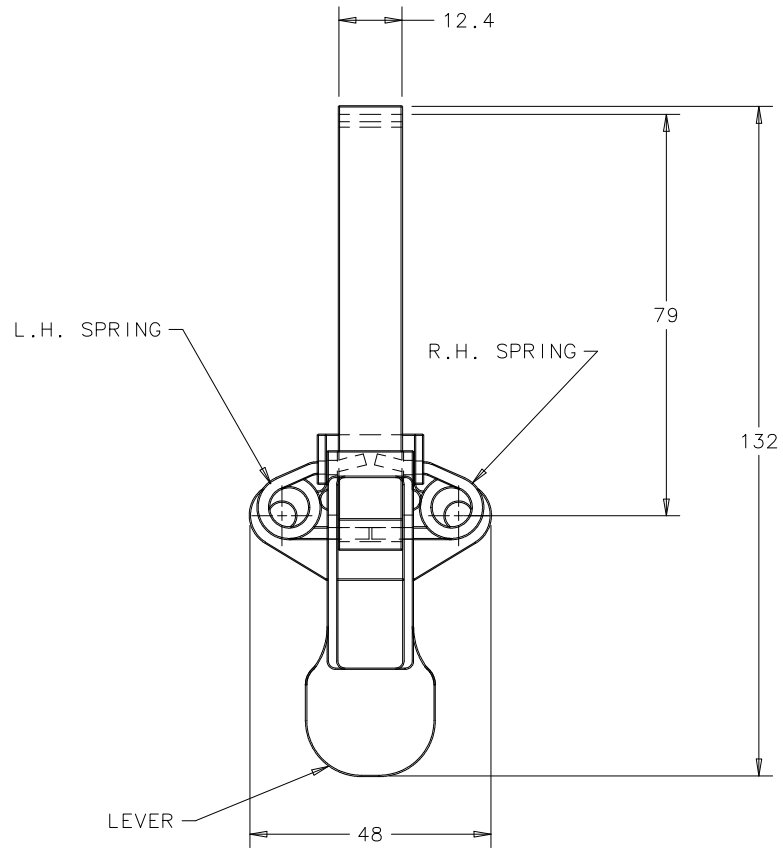

NOTES:
 A. ANCHOR PLATE AND LEVER: CARBON STEEL
 SPRINGS: SPRING STEEL
 BLADE: CARBON STEEL, HEAT TREATED.

B. SPRING LOADED ANCHOR PLATE COMPENSATES UP TO 2.3mm FOR IRREGULARITIES IN SEALING SURFACES AND GASKET SET.

