

| REVISION HISTORY | | | |
|------------------|-----------|---------|-----------------|
| REV | DATE | BY | DESCRIPTION |
| C | 17MAY2022 | CMS/CTG | PRN: P2022-0794 |

PART NUMBER C2-43-21 SHOWN

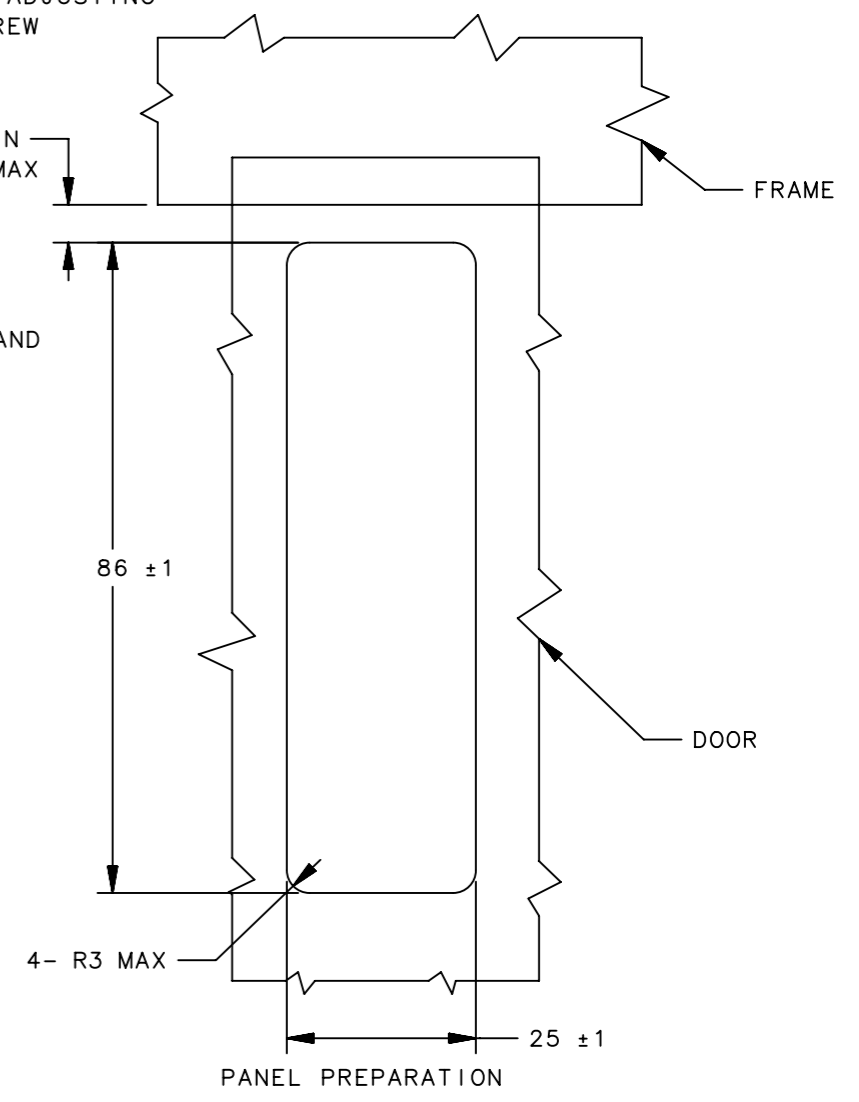
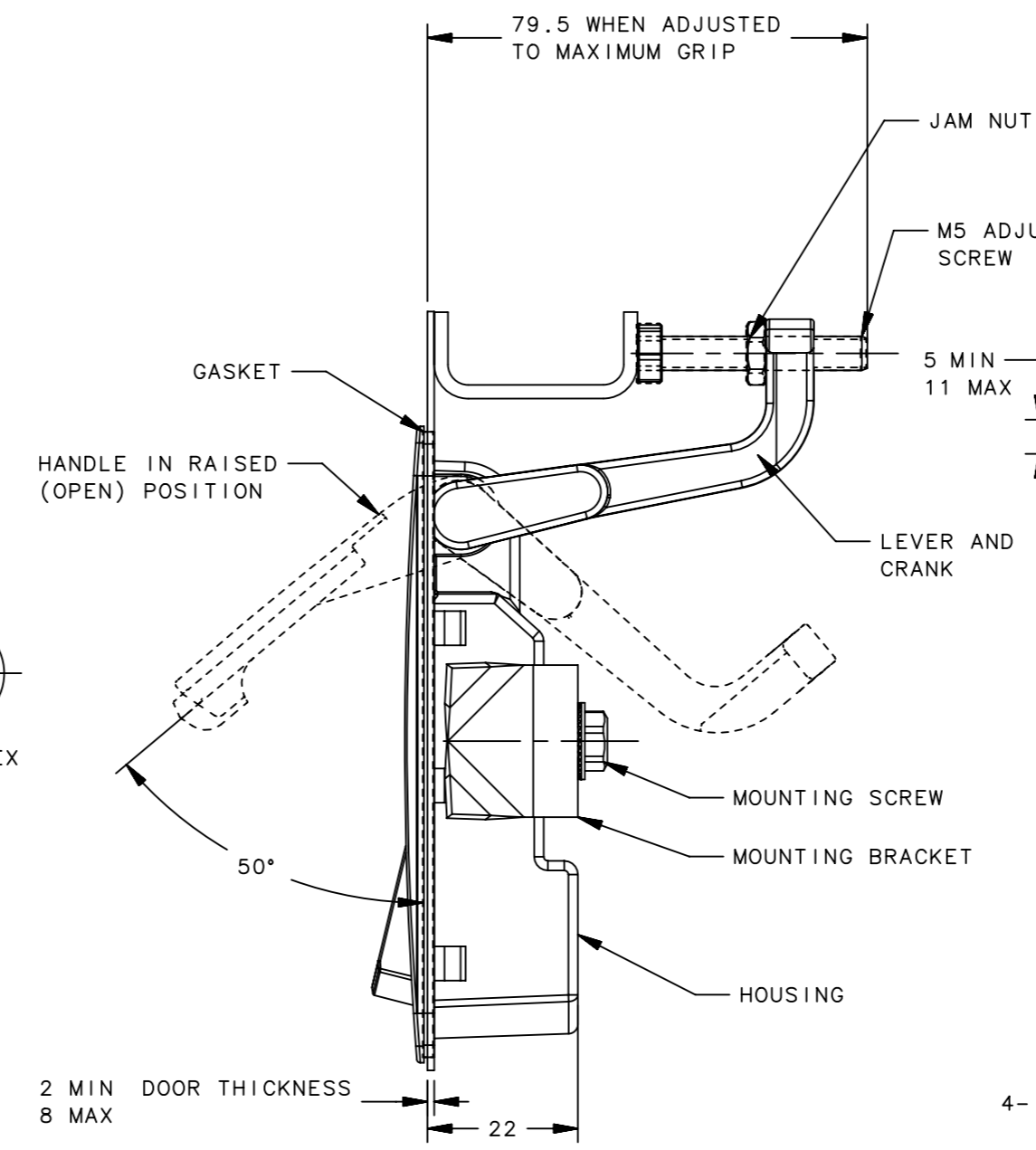
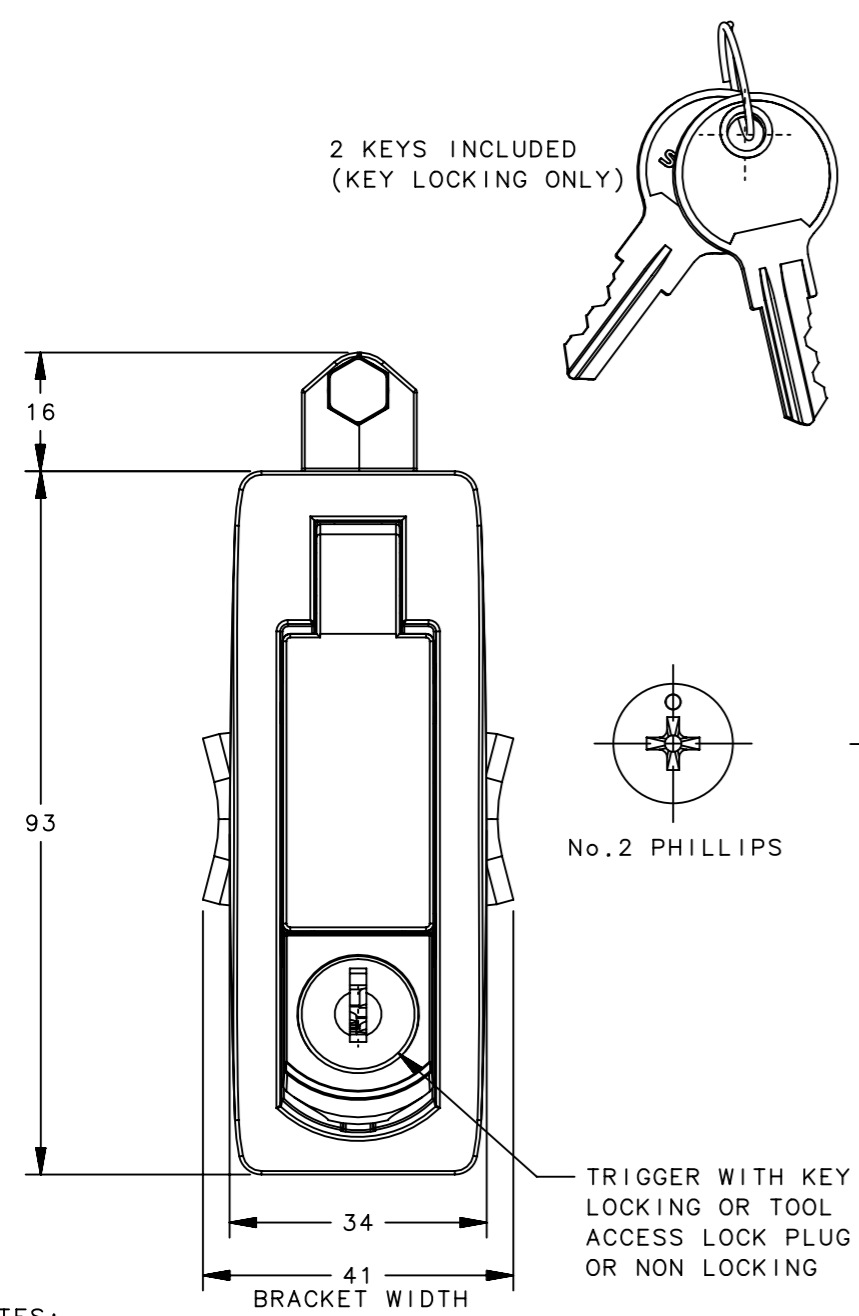
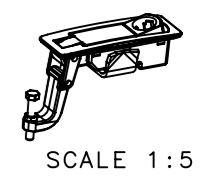

NOTES:

- A. MATERIAL AND FINISH**
- HOUSING, HANDLE, LOCK PLUG AND TRIGGER: DIE CAST ZINC. SEE ASSEMBLY PART NUMBER TABLE.
 - LEVER AND CRANK: DIE CAST ZINC, ZINC PLATE.
 - ADJUSTING SCREW, MOUNTING BRACKET, MOUNTING SCREW AND JAM NUT: STEEL, ZINC PLATE.
 - GASKET: NEOPRENE, NATURAL.
 - O-RING: RUBBER, NATURAL.
 - TORSION SPRING: STAINLESS STEEL, NATURAL.
 - U-SPRING: STAINLESS STEEL, PASSIVATED.
 - KEY: BRASS, NICKEL PLATED.
- B. LATCH INSTALLATION:**
- PLACE GASKET UNDER LIP OF HOUSING AND PLACE LATCH INTO PANEL PREP.
 - INSERT MOUNTING SCREW INTO MOUNTING BRACKET AND SCREW INTO HOUSING. MOUNTING SCREW IS AN M5 SCREW. USE LONGER SCREWS (NOT SUPPLIED) FOR THICKER DOORS. MAXIMUM MOUNTING BOLT TORQUE 4.5 N.m (30lbf.in).
 - ADJUST ADJUSTING SCREW TO REQUIRED GRIP AND TIGHTEN JAM NUT. MAXIMUM JAM NUT TORQUE 4 N.m (35.4 lbf.in).
- C. LOCK PLUG INSTALLATION:**
- POSITION LOCK PLUG AND ORIENT RETAINING WAFER (LAST WAFER LOCATED AT THE BOTTOM OF LOCK) AT THE 9 O'CLOCK POSITION AND INSERT INTO THE TRIGGER.
 - BE SURE THE LOCK PLUG IS FULLY SEATED AGAINST THE TRIGGER.

| TRIGGER OPTION | ASSEMBLY PART NUMBER | |
|----------------------|----------------------|------------------------|
| | BLACK POWDER COATED | TEXTURED CHROME FINISH |
| NON LOCKING (RAISED) | C2-43-15 | C2-43-11 |
| NON LOCKING (FLUSH) | C2-43-35 | C2-43-31 |
| RAILWAY STANDARD | C2-43-145 | C2-43-141 |

| TRIGGER OPTION | ASSEMBLY PART NUMBER | |
|-------------------|----------------------|------------------------|
| | BLACK POWDER COATED | TEXTURED CHROME FINISH |
| KEY LOCKING | C2-43-25 | C2-43-21 |
| 4mm HEX | C2-43-45 | C2-43-41 |
| NO. 2 PHILLIPS | C2-43-105 | C2-43-101 |
| WITHOUT LOCK PLUG | C2-43-135 | C2-43-131 |

| | | | |
|--|----------------------|--|-----------|
| THIRD ANGLE PROJECTION | | CONNECT · CREATE · INNOVATE | |
| MILLIMETERS [IN] | | | |
| TOLERANCES UNLESS OTHERWISE NOTED | | DESCRIPTION | |
| ALL DIMENSIONS WITHOUT TOLERANCES ARE FOR REFERENCE ONLY. | | SEALED C2 LEVER LATCH ASSEMBLY LOCKING TRIGGER | |
| PROPRIETARY ITEM | PER ASME Y14.5M-1994 | SIZE A3 | SYSTEM NX |
| EXCEPT FOR USES EXPRESSLY GRANTED IN WRITING, INFORMATION DISCLOSED HEREON IS CONFIDENTIAL AND ALL RIGHTS, PATENT AND OTHERWISE, ARE RESERVED BY SOUTHCO, INC. | | DWG NO. | J-C2-43 |
| | | DRAWN BY | JQ |
| | | DATE | 07MAY2014 |
| | | SCALE | 1:1 |
| | | SHEET | 1 OF 1 |