

CN Inject / Eject Mechanism

Ejectors

Material and Finish

Module ejector:

Lever and slide:

Glass-filled nylon, white

Base: Die-cast zinc, nickel plated

Pin and spring: Stainless steel, passivated

Blanking panel ejector:

Lever: Glass-filled nylon, white

Base: Polycarbonate, white

Pin: Stainless steel, passivated

Mini module ejector:

Lever and catch:

Polycarbonate, gray

Base: Die-cast zinc, natural

Pin: Stainless steel, passivated

Performance Details

Flammability rating: UL94-V0 rated plastic components

Module Ejector

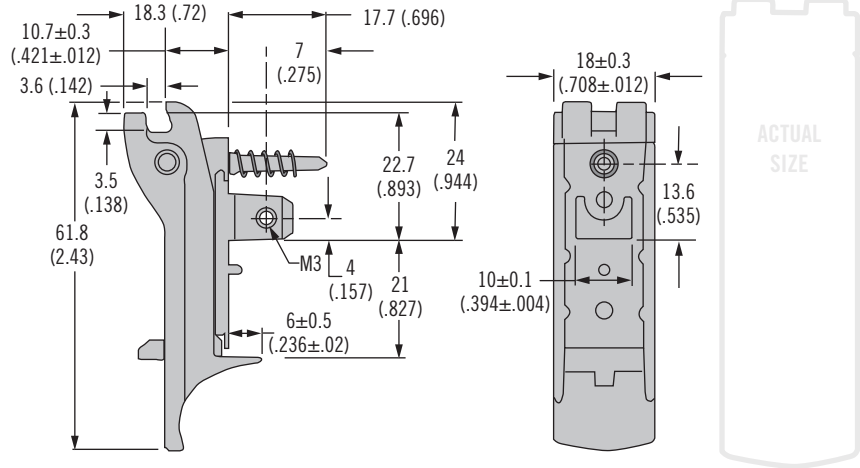

Blanking Panel Ejector

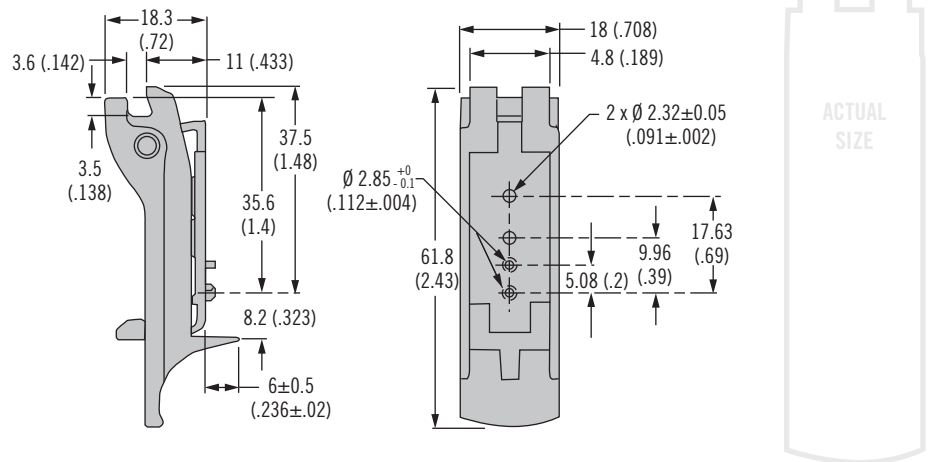

Mini Module Ejector

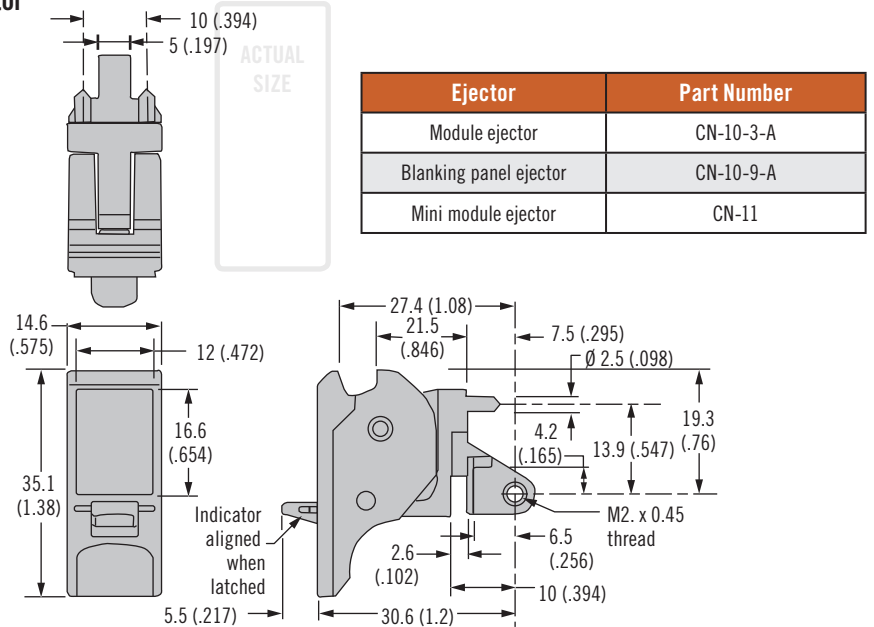

Ejector	Part Number
Module ejector	CN-10-3-A
Blanking panel ejector	CN-10-9-A
Mini module ejector	CN-11