



P7 AdvancedMC[®] Inject / Eject Mechanism

Module handle & light pipe bracket panel preparation

- Die-cast construction for robust performance
- Handle operation controls hot swap activation
- Handle retention feature prevents accidental operation
- For use with Carriers supporting 4 Full-size AMC Modules

Material and Finish

Handle: Zinc alloy, black chrome
 Lever: Zinc alloy, bright chromate
 Pivot screw, Drag spring: Steel, zinc plated
 Shoulder screw, U-bent washer: Stainless steel, passivated

Performance Details

Flammability rating: UL94-V0

Installation Notes

See page 583

Upper Handle Assembly

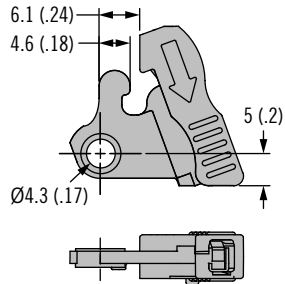

Lower Handle Assembly

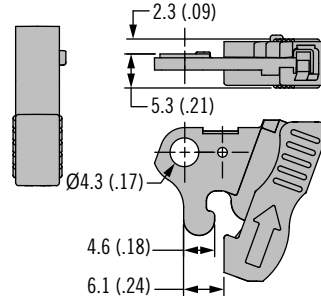

Switch Arm

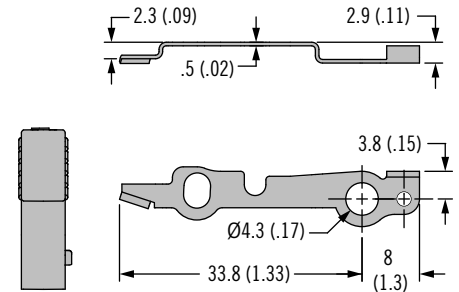

Pivot Screw (2 supplied)

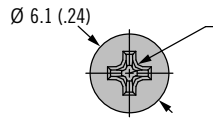

Shoulder Screw (supplied)

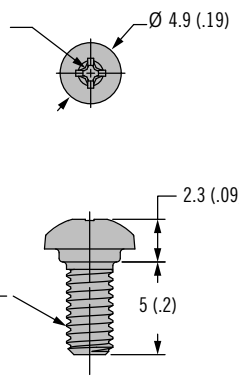

U-Bent Washer (2 supplied)

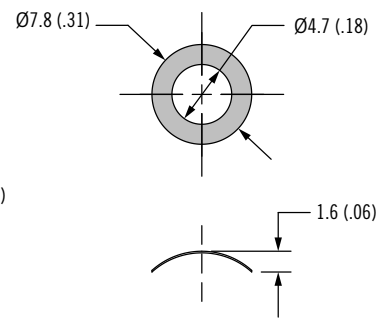

Part Number
P7-C-701
Part Number includes Upper and Lower Handle Assemblies, Switch Arm, Pivot Screws, Shoulder Screw and U-Bent Washers as shown

Panel Preparation

Upper handle location

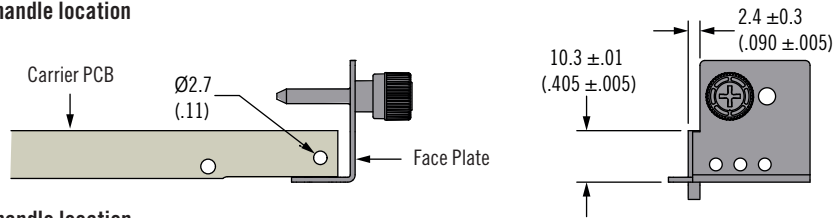

Lower handle location

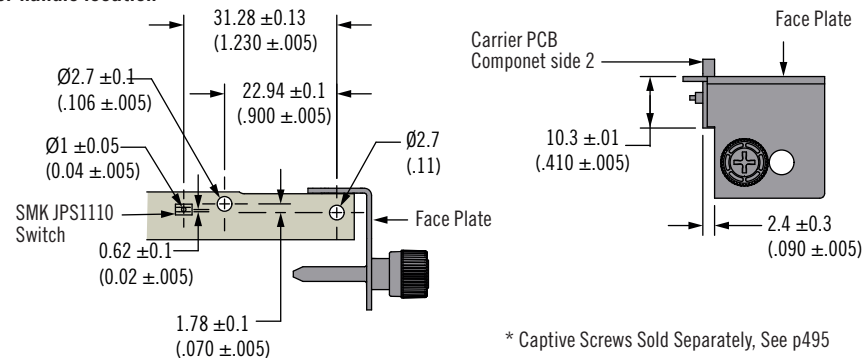

* Captive Screws Sold Separately, See p495

AdvancedMC is a registered trademark of PICMG[®] - PCI Industrial Computer Manufacturers Group, Inc.

Installation

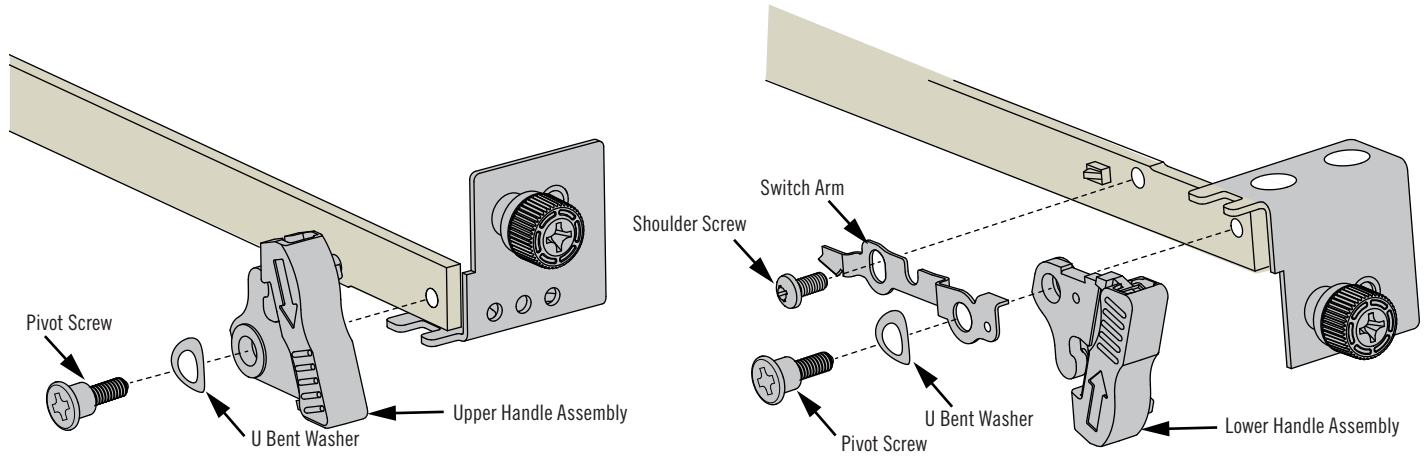

Tap M2.5 Threads into Carrier (not shown) to accept Pivot Screw and Shoulder Screw
Tighten screws to 45-60N-cm

Operation

Handle stowed, carrier inserted, Hot swap switch activated

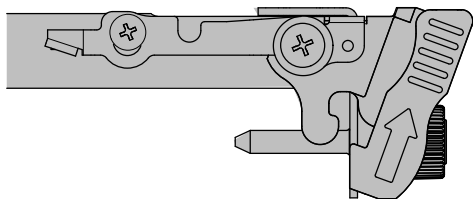

Handle extended, carrier inserted, Hot swap switch activated

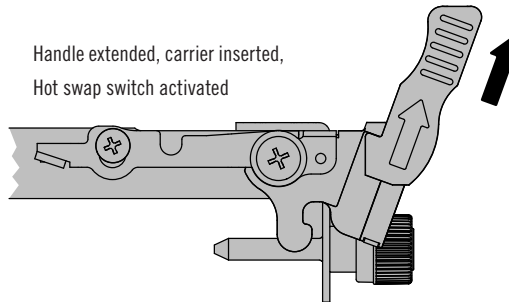

Handle extended, carrier inserted, Hot swap switch de-activated

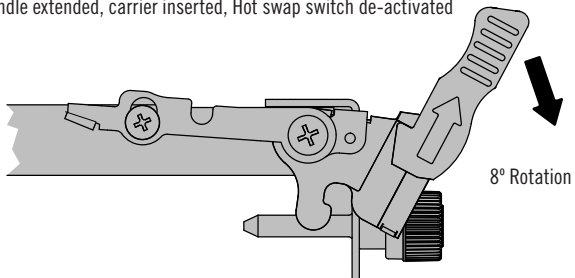

Handle extended, carrier extracted, Hot swap switch de-activated

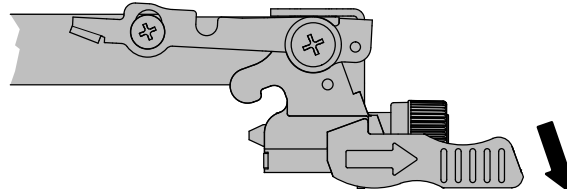

AdvancedMC is a registered trademark of PICMG[®] - PCI Industrial Computer Manufacturers Group, Inc.

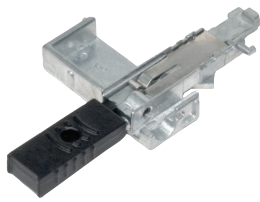

P7 AdvancedMC® Inject / Eject Mechanism

Pull module handle

- Die-cast construction for robust performance
- Positive detent at three distinct positions
- Fits all current microswitch locations
- Custom colors available

Material and Finish

Handle/shaft, housing and catch:
Zinc alloy, bright chromate

Notes

*Order light pipes separately

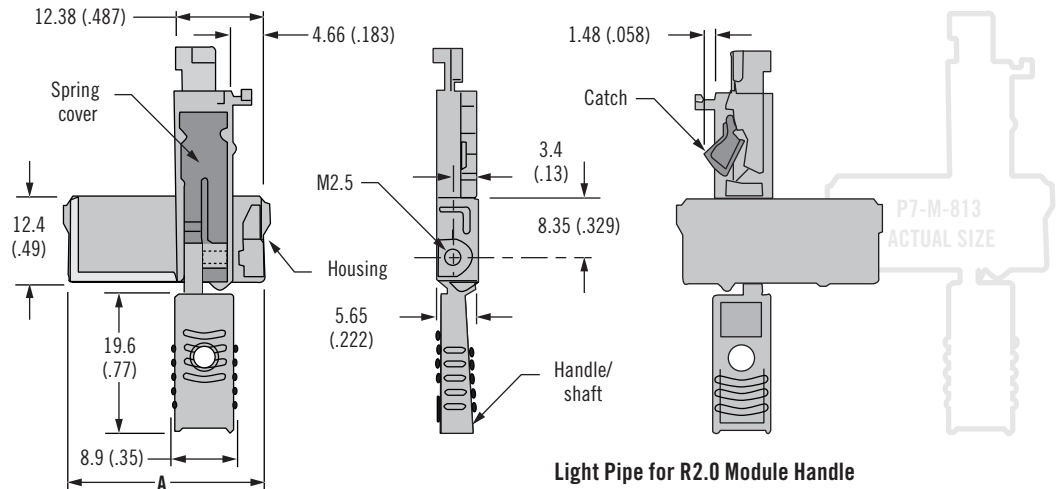

Part Number		Handle Size	A
Module handle	R2.0 Light pipe*		
P7-M-811-000	P7-10-812	Compact 3HP	12.50 (.492)
P7-M-812-000	P7-10-812	Mid size 4HP	17.55 (.691)
P7-M-813-000	P7-10-812	Full size 6HP	27.55 (1.085)

Light Pipe for R2.0 Module Handle

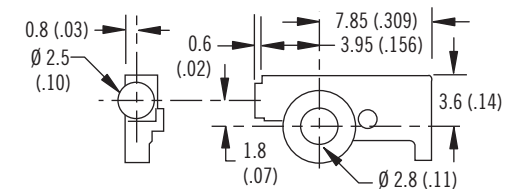

www.southco.com/P7

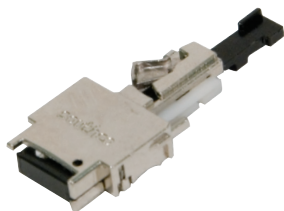

P7 AdvancedMC® Inject / Eject Mechanism

Flush module handle

- Flush button prevents snagging of handle
- Flush button allows for better aesthetics
- Locking pin feature

Material and Finish

Handle/shaft: Zinc alloy, black epoxy coat

Housing, cover and catch: Zinc alloy, bright nickel plate

Light pipe: Polycarbonate clear

AdvancedMC is a registered trademark of PICMG® - PCI Industrial Computer Manufacturers Group, Inc.

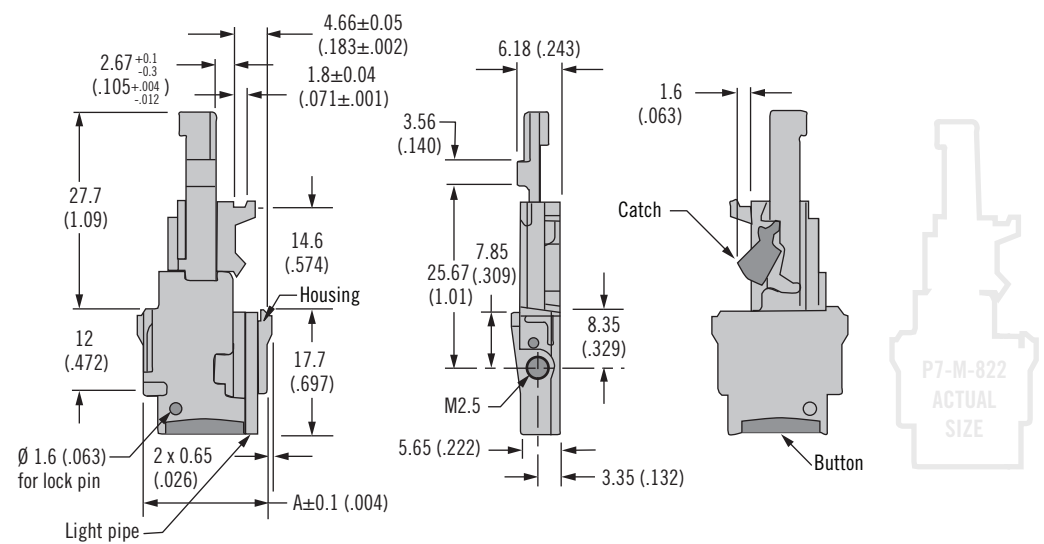

Part Number	Handle Size	A
P7-M-822	Mid size 4HP	17.55 (.691)
P7-M-823	Full size 6HP	27.55 (1.085)

Dimensions in millimeters (inch) unless otherwise stated

www.southco.com/P7



P7 AdvancedMC[®] Inject / Eject Mechanism Operation

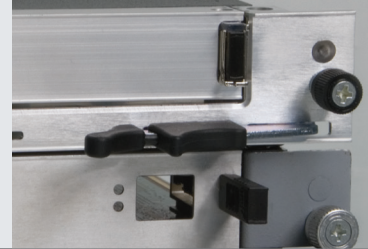

Operation

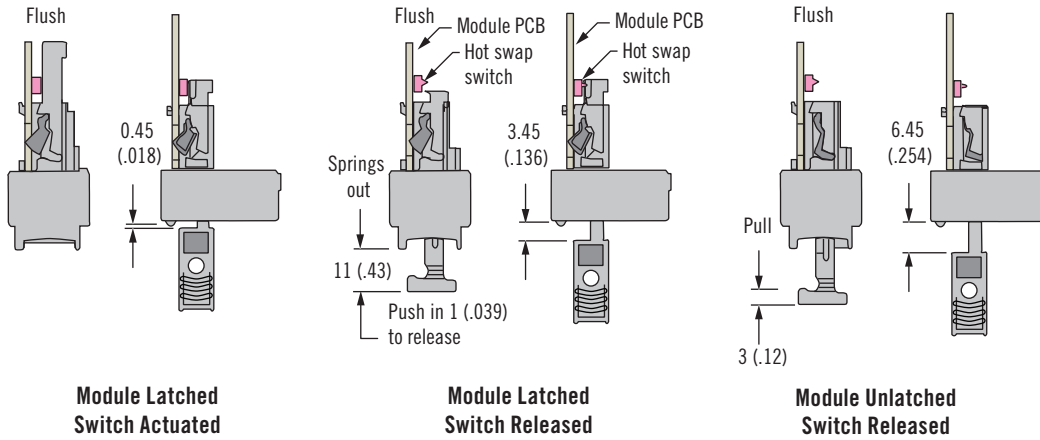

www.southco.com/P7

P7 AdvancedMC[®] Light Pipe Bracket



R2.0

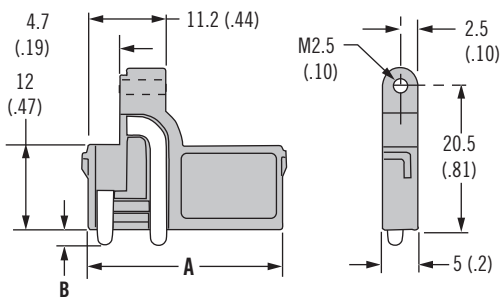

Part Number	Bracket Size	A	B
P7-L-811	Compact	12.50 (.492)	2.1 (.08)
P7-L-812	Mid size	17.55 (.691)	
P7-L-813	Full size	27.55 (1.085)	
P7-L-811-11	Compact flush	12.50 (.492)	0.3 (.012)
P7-L-812-11	Mid size flush	17.55 (.691)	
P7-L-813-11	Full size flush	27.55 (1.085)	

- Easily snaps into faceplate
- Bracket includes light pipe and housing
- Compatibility with all standard Advanced MC[®] faceplates

Material and Finish

Light pipe housing: Zinc alloy, bright chromate
 Light pipe: Polycarbonate, clear

Notes

For R1.0 light pipe bracket go to www.southco.com

AdvancedMC is a registered trademark of PICMG[®] - PCI Industrial Computer Manufacturers Group, Inc.

P7 AdvancedMC[®] Inject / Eject Mechanism

Module handle & light pipe bracket panel preparation

Installation Notes

1. Snap handle assembly and light pipe bracket into faceplate.
2. For R2.0, position blue LED light pipe into handle assembly and faceplate. Light pipe should be positioned against outside wall of handle assembly.
3. Slide PCB in place and secure with screws. Blue LED light pipe is located on component side 2 of the PCB.

Notes

All panel preparation tolerances ± 0.1 (.004)

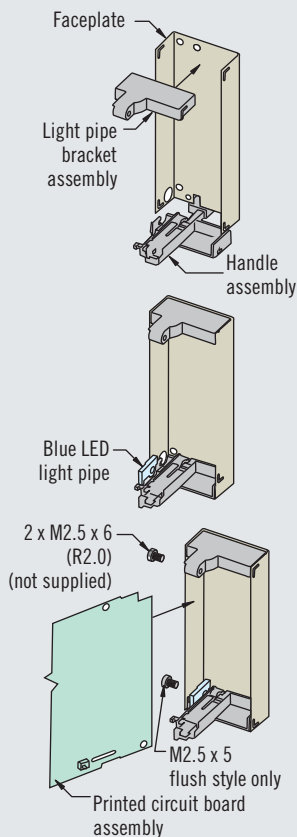

AdvancedMC is a registered trademark of PICMG[®] - PCI Industrial Computer Manufacturers Group, Inc.

Panel Preparation Light Pipe Brackets

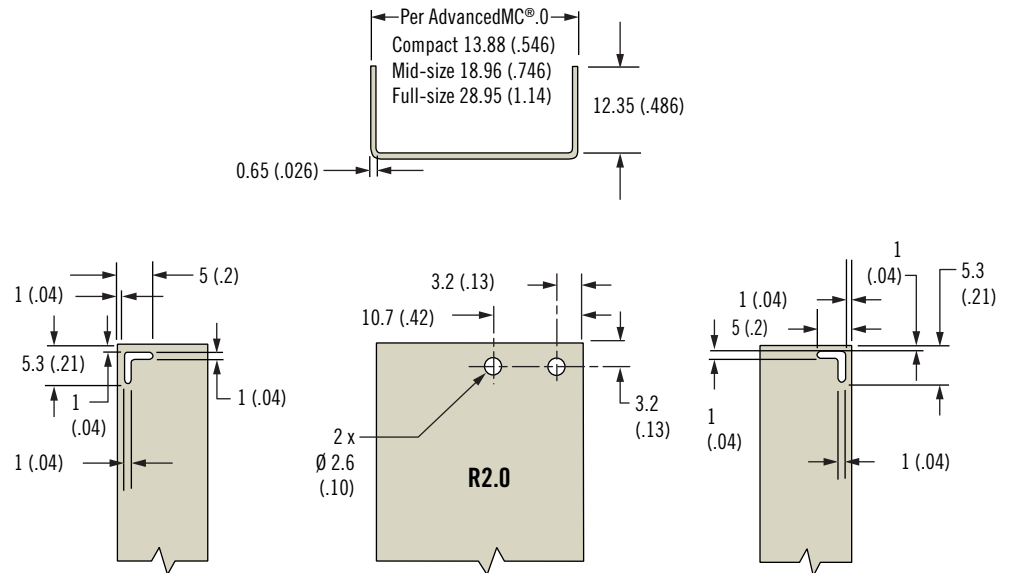

Panel Preparation Module Handles

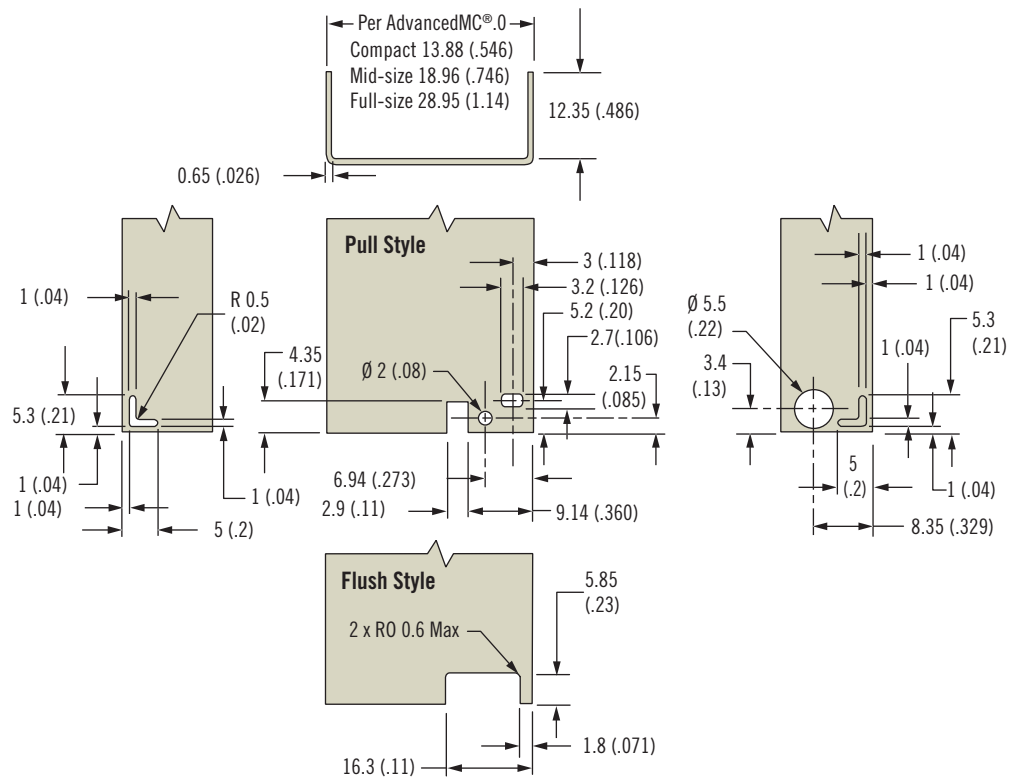

Dimensions in millimeters (inch) unless otherwise stated

PCB Preparation

Printed Circuit Board Component Side 1

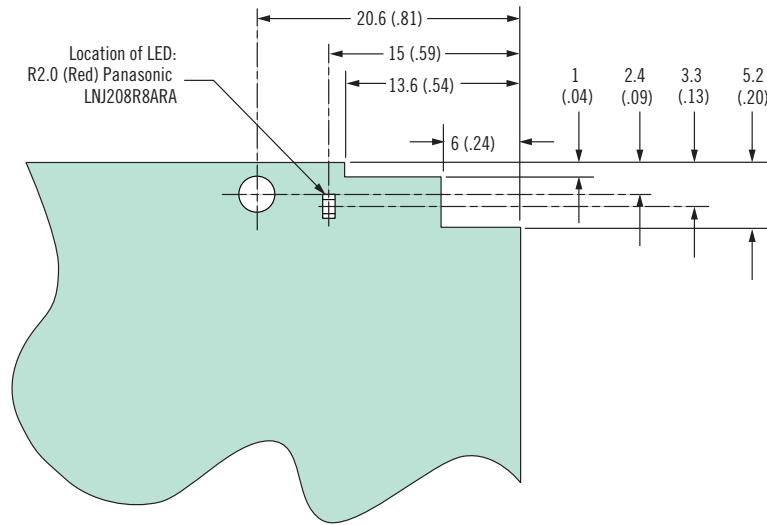

Printed Circuit Board Component Side 2

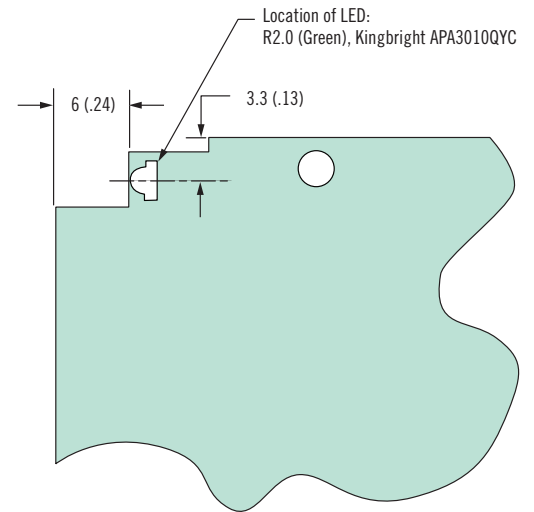

Printed Circuit Board Component Side 1

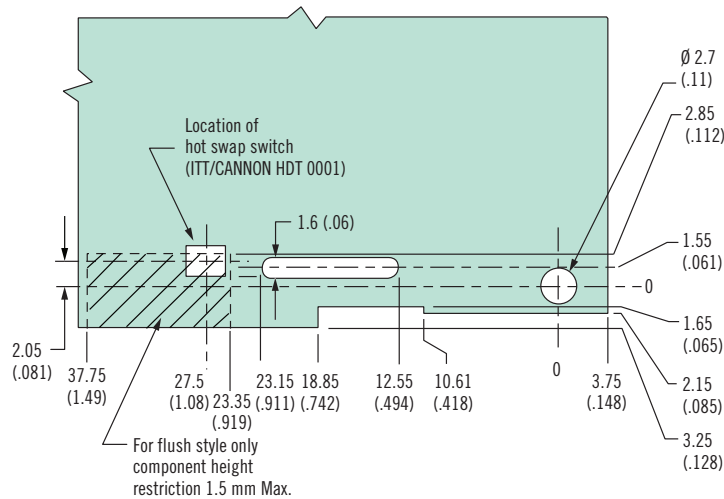

Printed Circuit Board Component Side 2

