

PROPRIETARY ITEM - EXCEPT FOR USES EXPRESSLY GRANTED IN WRITING, INFORMATION DISCLOSED HEREON IS CONFIDENTIAL AND ALL RIGHTS PATENT AND OTHERWISE ARE RESERVED BY SOUTHCO, INC.

No. 12 RETAINERS

DRAWING NUMBER	DRAWN	CHKD	SCALE
TD-12-2-J	CLB	ACZ	NTS
	DATE		
	7-6-89		



SOUTHCO PERFORMANCE GUIDELINES
 THE PERFORMANCE GUIDELINES SHOWN ON THIS PAGE ARE SUPPLIED AS A GENERAL GUIDE ONLY, AS CONDITIONS VARY WITH EACH APPLICATION AND METHOD OF INSTALLATION. STRENGTH DATA GIVEN IS FOR FAILURE OF THE PRODUCT OR FOR SUFFICIENT DEFORMATION TO MAKE PRODUCT INOPERABLE. NO SAFETY FACTOR HAS BEEN APPLIED IT IS RECOMMENDED THAT THE USER REQUEST A PRODUCT SAMPLE FOR TESTING TO DETERMINE THE SUITABILITY OF THE PRODUCT FOR THE PURPOSE INTENDED AND USER'S PARTICULAR APPLICATION.

INSTALLATION FORCE

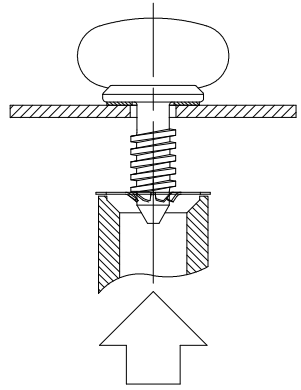

RETENTION FORCE

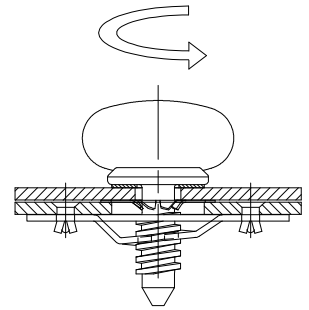
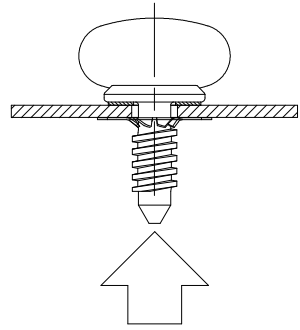

BACK OUT TORQUE

NOTE: Retainer shown is P/N 12-6-1.

PART NUMBER (DESCRIPTION)	AVERAGE INSTALLATION FORCE (N/lb) ^(A)	AVERAGE RETENTION FORCE (N/lb) ^(B)	AVERAGE BACK OUT TORQUE (N-m/in-lb) ^(C)
12-6-1 (S/S, PUSH-ON)	72.9/16.4	1632/367 ⁽¹⁾	1.23/11.0 ⁽⁴⁾
12-11014-12 (ALUM, THREAD-ON AND FLATTEN)	86.3/19.4	885/199 ⁽²⁾	0.67/6.0 ⁽⁴⁾
12-11014-26 (S/S, THREAD-ON AND FLATTEN)	152.7/34.3	2171/488 ⁽²⁾	1.06/9.5 ⁽⁴⁾
12-11064-42 (NYLON, PUSH-ON)	44.9/10.1	383/86 ⁽³⁾	0.67/6.0 ⁽⁴⁾

- ^(A) Installation force is the force required to:
 1. push retainer P/N 12-6-1 or P/N 12-11064-42 over the screw threads with installation tool No. 12-0-20980-11 as shown.
 2. strike tool No. 12-11019-11 in order to flatten retainer P/N 12-11014-12 or P/N 12-11014-26.
- ^(B) Retention force is the force required to push the screw out of the retainer as shown.
- ^(C) Back out torque is the torque required to unthread the screw through the retainer when outer and inner panels are held adjacent to one another and a standard receptacle is used as shown.

FAILURE MODES:

- ⁽¹⁾ Retainer teeth bent and broke off.
- ⁽²⁾ Retainer bent and cracked.
- ⁽³⁾ Retainer bent and ripped.
- ⁽⁴⁾ Retainer bent.

REF. 12-59

southco

REV	DATE	DRAWN/CHKD	DESCRIPTION	UPDATE FORMAT
B	09APR2002	GDM		