

REV	A	DATE	09APR2002	GM	DESCRIPTION	UPDATE FORMAT	DATE	DRAWN/CHKD	GDM	PROPRIETARY ITEM - EXCEPT FOR USES EXPRESSLY GRANTED IN WRITING, INFORMATION DISCLOSED HEREON IS CONFIDENTIAL AND ALL RIGHTS, PATENT AND OTHERWISE ARE RESERVED BY SOUTHCO, INC.	No. 85 LEAF SPRING RECEPTACLE SIDE MOUNT	DATE	03JAN94	ALC	ACZ	NTS	SCALE	DRAWN/CHKD	SCALE	DRAWING NUMBER	TD-85-8-J	THIRD ANGLE PROJECTION	A PAPER SIZE

SOUTHCO PERFORMANCE GUIDELINES
 THE PERFORMANCE GUIDELINES SHOWN ON THIS PAGE ARE SUPPLIED AS A GENERAL GUIDE ONLY, AS CONDITIONS VARY WITH EACH APPLICATION AND METHOD OF INSTALLATION. STRENGTH DATA GIVEN IS FOR FAILURE OF THE PRODUCT OR FOR SUFFICIENT DEFORMATION TO MAKE PRODUCT INOPERABLE. NO SAFETY FACTOR HAS BEEN APPLIED IT IS RECOMMENDED THAT THE USER REQUEST A PRODUCT SAMPLE FOR TESTING TO DETERMINE THE SUITABILITY OF THE PRODUCT FOR THE PURPOSE INTENDED AND USER'S PARTICULAR APPLICATION.

ALL STRENGTH RATINGS ARE INDEPENDENT OF HEAD STYLE.

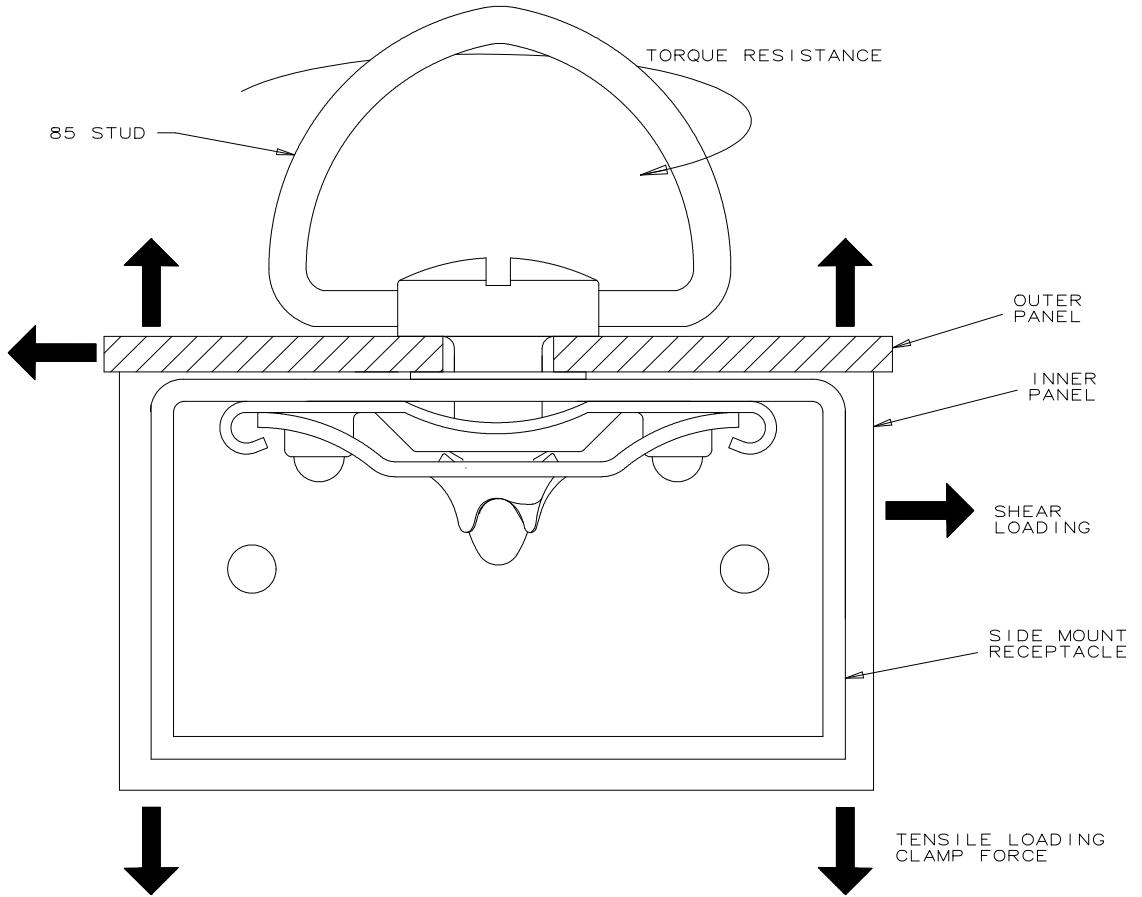

PART NUMBER	85-45-101-15
MATERIAL	STEEL
MAXIMUM RECOMMENDED WORKING TENSILE STRENGTH ①	2000 N (450 LBS)
AVERAGE ULTIMATE TENSILE STRENGTH ②	6000 N (1350 LBS)
CLAMP FORCE ③	180 N (40 LBS)
MAXIMUM RECOMMENDED WORKING SHEAR STRENGTH ①	1330 N (300 LBS)
AVERAGE ULTIMATE SHEAR STRENGTH ②	3110 N (700 LBS)
MAXIMUM TORQUE RESISTANCE ④	8.5 Nm (75 IN-LBS)

- ① WORKING LOAD is the maximum force that the product will withstand without affecting the operation or appearance of the product.
- ② Average ULTIMATE LOAD causes failure of the product or sufficient deformation to make the product inoperable.
- ③ CLAMP FORCE is the force applied to the panel when the assembly is latched at the nominal grip.
- ④ MAXIMUM TORQUE RESISTANCE is the torque that causes the stud to override the receptacle stop.

REF: 85-19

southco