



PROPRIETARY ITEM - EXCEPT FOR USES EXPRESSLY GRANTED IN WRITING INFORMATION DISCLOSED HEREON IS CONFIDENTIAL AND ALL RIGHTS PATENT AND OTHERWISE ARE RESERVED BY SOUTHCO, INC.

No. A7 OVER-CENTER DRAW LATCH

DATE	DRAWN	CHKD	SCALE	DRAWING NUMBER
01OCT93	ALC	ACZ	NTS	TD-A7-1-J

REV	DATE	DRAWN/CHKD	DESCRIPTION						
A	09APR2002	GDM	UPDATE FORMAT						

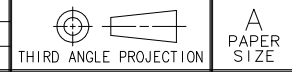

SOUTHCO PERFORMANCE GUIDELINES  
 THE PERFORMANCE GUIDELINES SHOWN ON THIS PAGE ARE SUPPLIED AS A GENERAL GUIDE ONLY, AS CONDITIONS VARY WITH EACH APPLICATION AND METHOD OF INSTALLATION. STRENGTH DATA GIVEN IS FOR FAILURE OF THE PRODUCT OR FOR SUFFICIENT DEFORMATION TO MAKE PRODUCT INOPERABLE. NO SAFETY FACTOR HAS BEEN APPLIED. IT IS RECOMMENDED THAT THE USER REQUEST A PRODUCT SAMPLE FOR TESTING TO DETERMINE THE SUITABILITY OF THE PRODUCT FOR THE PURPOSE INTENDED AND USER'S PARTICULAR APPLICATION.

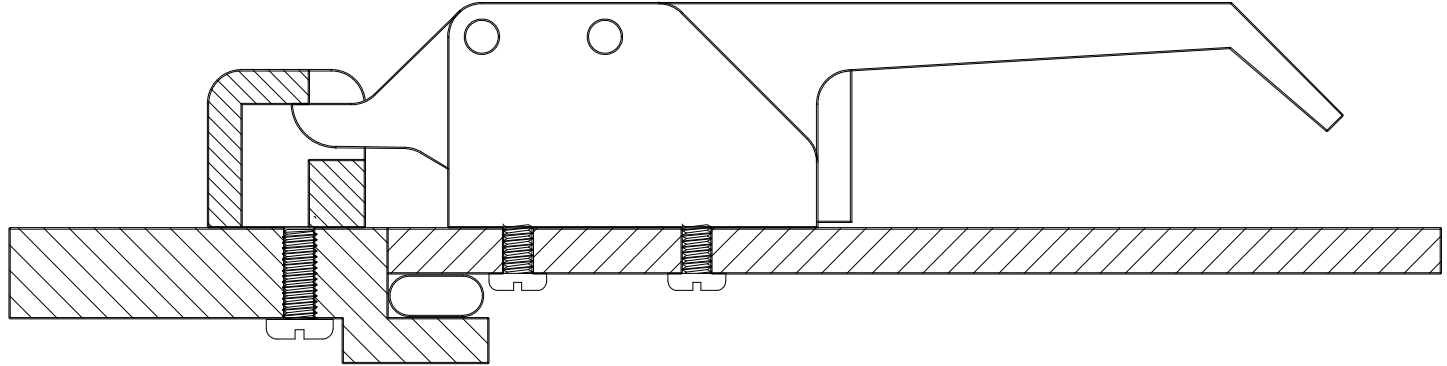

PART NUMBER	MOUNTING SCREW THREAD SIZE	AVERAGE CLAMPING FORCE (C)	MAXIMUM RECOMMENDED WORKING LOAD (A)	AVERAGE ULTIMATE LOAD (B)
A7-10-301-XX	#10-32 X .38 IN	1340 N (300 LBS)	2230 N (500 LBS)	4450 N (1000 LBS)
A7-10-302-XX				
A7-10-351-XX	M5-0.8 X 9.5 mm	1340 N (300 LBS)	2230 N (500 LBS)	4450 N (1000 LBS)
A7-10-352-XX				

- (A) WORKING LOAD is the maximum recommended load at which the product continues to function properly.
- (B) ULTIMATE LOAD is the load that causes excessive pawl deformation, which renders the product inoperable.
- (C) CLAMP LOAD is the load between the keeper and the handle assy. when the two mounting surfaces are in plane.