

REV	DATE	DRAWN/CHKD	DESCRIPTION

THIRD ANGLE PROJECTION  A4 PAPER SIZE

SOUTHCO PERFORMANCE GUIDELINES
 THE PERFORMANCE GUIDELINES SHOWN ON THIS PAGE ARE SUPPLIED AS A GENERAL GUIDE ONLY, AS CONDITIONS VARY WITH EACH APPLICATION AND METHOD OF INSTALLATION. STRENGTH DATA GIVEN IS FOR FAILURE OF THE PRODUCT OR FOR SUFFICIENT DEFORMATION TO MAKE PRODUCT INOPERABLE. NO SAFETY FACTOR HAS BEEN APPLIED IT IS RECOMMENDED THAT THE USER REQUEST A PRODUCT SAMPLE FOR TESTING TO DETERMINE THE SUITABILITY OF THE PRODUCT FOR THE PURPOSE INTENDED AND USER'S PARTICULAR APPLICATION.

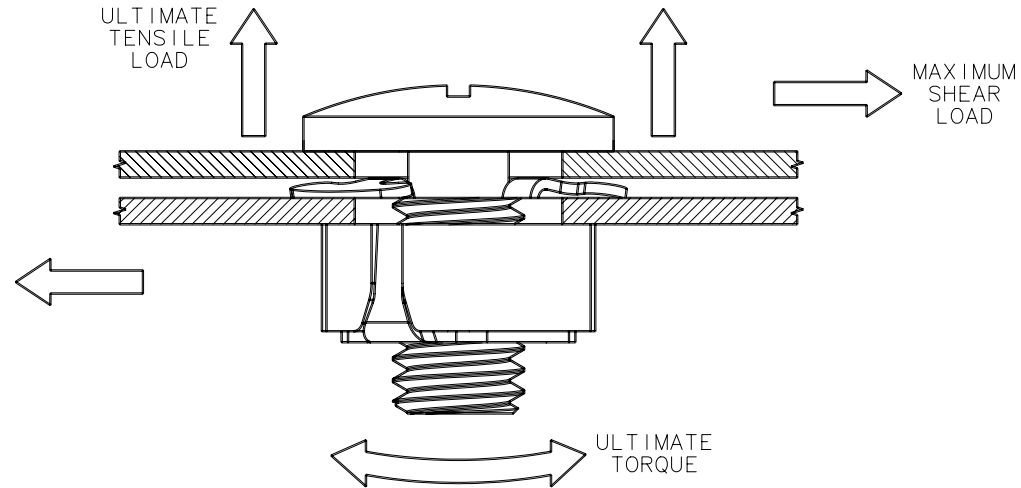

PART NUMBER	RECOMMENDED MAXIMUM TIGHTENING TORQUE	AVERAGE ULTIMATE TORQUE ①	AVERAGE ULTIMATE TENSILE LOAD ②	MAXIMUM SHEAR LOAD ③
DM-95-10	10 N • m	15 N • m	1150 N	1000 N

AVERAGE ULTIMATE LOAD - is the load that causes failure or excessive deformation which renders the product inoperable.

Overloading the fastener beyond these conditions is not recommended.

- ① Threads stripped.
- ② Panels deformed.
- ③ Panels failed.
- ④ All testing done using steel screws.