

SOUTHCO PERFORMANCE GUIDELINES

REVISION HISTORY			
REV	DATE	BY	DESCRIPTION
C	24OCT2016	NX/IW	PRN: P2016-2333

THE PERFORMANCE GUIDELINES SHOWN ON THIS PAGE ARE SUPPLIED AS A GENERAL GUIDE ONLY, AS CONDITIONS VARY WITH EACH APPLICATION AND METHOD OF INSTALLATION, STRENGTH DATA GIVEN IS FOR FAILURE OF THE PRODUCT OR FOR SUFFICIENT DEFORMATION TO MAKE THE PRODUCT INOPERABLE. NO SAFETY FACTOR HAS BEEN APPLIED. IT IS RECOMMENDED THAT THE USER REQUEST A PRODUCT SAMPLE FOR TESTING TO DETERMINE THE SUITABILITY OF THE PRODUCT FOR THE PURPOSE INTENDED AND USER'S PARTICULAR APPLICATION.

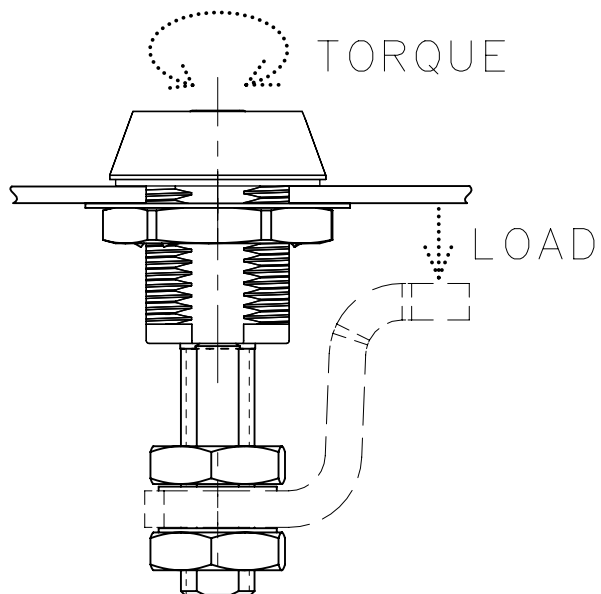

PART NUMBER: E3-CRH-OF

AVERAGE ULTIMATE LOAD: 1600N (360 lbf)

RECOMMENDED TIGHTENING TORQUE - MOUNTING NUT: 20 Nm (177 lbf in)
 - MOUNTING SCREW: 10Nm (88.5 lbf in)

CYCLE TEST - 10,000 CYCLES

AVERAGE ULTIMATE LOAD
 - THE LOAD THAT CAUSE FAILURE OR EXCESSIVE DEFORMATION WHICH RENDERS THE PRODUCT INOPERABLE.

REF: trE3-24209
 trE3-24939
 trE3-26858

	THIRD ANGLE PROJECTION	 CONNECT • CREATE • INNOVATE			
	MILLIMETERS [IN]				
	TOLERANCES UNLESS OTHERWISE NOTED	DESCRIPTION			
	ALL DIMENSIONS WITHOUT TOLERANCES ARE FOR REFERENCE ONLY.	COMPACT E3 ADJUSTABLE GRIP ZINC			
	PROPRIETARY ITEM EXCEPT FOR USES EXPRESSLY GRANTED IN WRITING, INFORMATION DISCLOSED HEREON IS CONFIDENTIAL AND ALL RIGHTS, PATENT AND OTHERWISE, ARE RESERVED BY SOUTHCO, INC.	SIZE A4	SYSTEM NX	DWG NO. TD-E3-C-12-3	
	PER ASME Y14.5M-1994	DRAWN BY NX/IW	DATE 27JUN2016	SCALE 1:1	SHEET 1 OF 1