

PART NUMBER	FORWARD TORQUE, Nm (in-lbf)	REVERSE TORQUE, Nm (in-lbf)	AVERAGE ULTIMATE RADIAL LOAD, N/lbf		AVERAGE ULTIMATE AXIAL LOAD, N/lbf	CYCLE LIFE	MAXIMUM WORKING LOAD, N/lbf ①	
			INLINE	PERPENDICULAR			AXIAL	RADIAL, INLINE
E6-70-400-XX	0.00 (0.00) REF	0.00 (0.00) REF						
E6-70-408S-XX	0.90 (8.0)	0.90 (8.0)						
E6-70-416S-XX	1.81 (16.0)	1.81 (16.0)						
E6-70-420S-XX	2.26 (20.0)	2.26 (20.0)						
E6-70-430S-XX	3.39 (30.0)	3.39 (30.0)						
E6-70-420F-XX	2.26 (20.0)	1.54 (13.6) REF	13,000/2922	13,000/2922	4000/899	20,000	200/45	200/45
E6-70-430F-XX	3.39 (30.0)	2.30 (20.4) REF						
E6-70-440F-XX	4.52 (40.0)	3.08 (27.3) REF						
E6-70-420R-XX	1.54 (13.6) REF	2.26 (20.0)						
E6-70-430R-XX	2.30 (20.4) REF	3.39 (30.0)						
E6-70-440R-XX	3.08 (27.3) REF	4.52 (40.0)						

REVISION HISTORY			
REV	DATE	BY	DESCRIPTION
B	17JUL2023	AJD/CRM	PRN: P2023-1103

① AXIAL AND RADIAL LOADS APPLIED ONE TIME TO A SINGLE HINGE WITHOUT DEGRADATION OF PERFORMANCE

SOUTHCO PERFORMANCE GUIDELINES:
 THE PERFORMANCE GUIDELINES SHOWN ON THIS PAGE ARE SUPPLIED AS A GENERAL GUIDE ONLY, AS CONDITIONS VARY WITH EACH APPLICATION AND METHOD OF INSTALLATION. STRENGTH DATA GIVEN IS FOR FAILURE OF THE PRODUCT OR FOR SUFFICIENT DEFORMATION TO MAKE THE PRODUCT INOPERABLE. NO SAFETY FACTOR HAS BEEN APPLIED. IT IS RECOMMENDED THAT THE USER REQUEST A PRODUCT SAMPLE FOR TESTING TO DETERMINE THE SUITABILITY OF THE PRODUCT FOR THE PURPOSE INTENDED AND THE USER'S PARTICULAR APPLICATION.

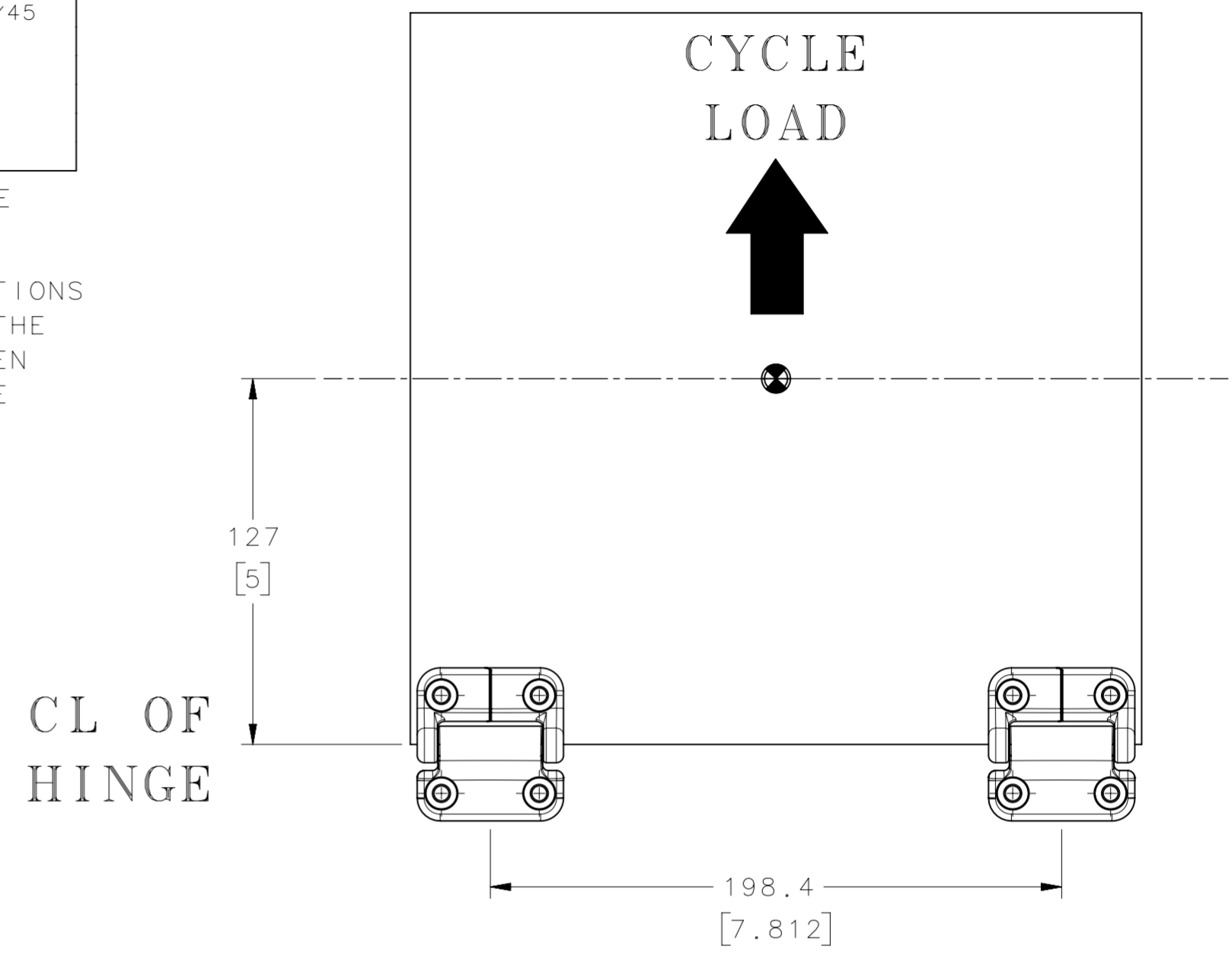
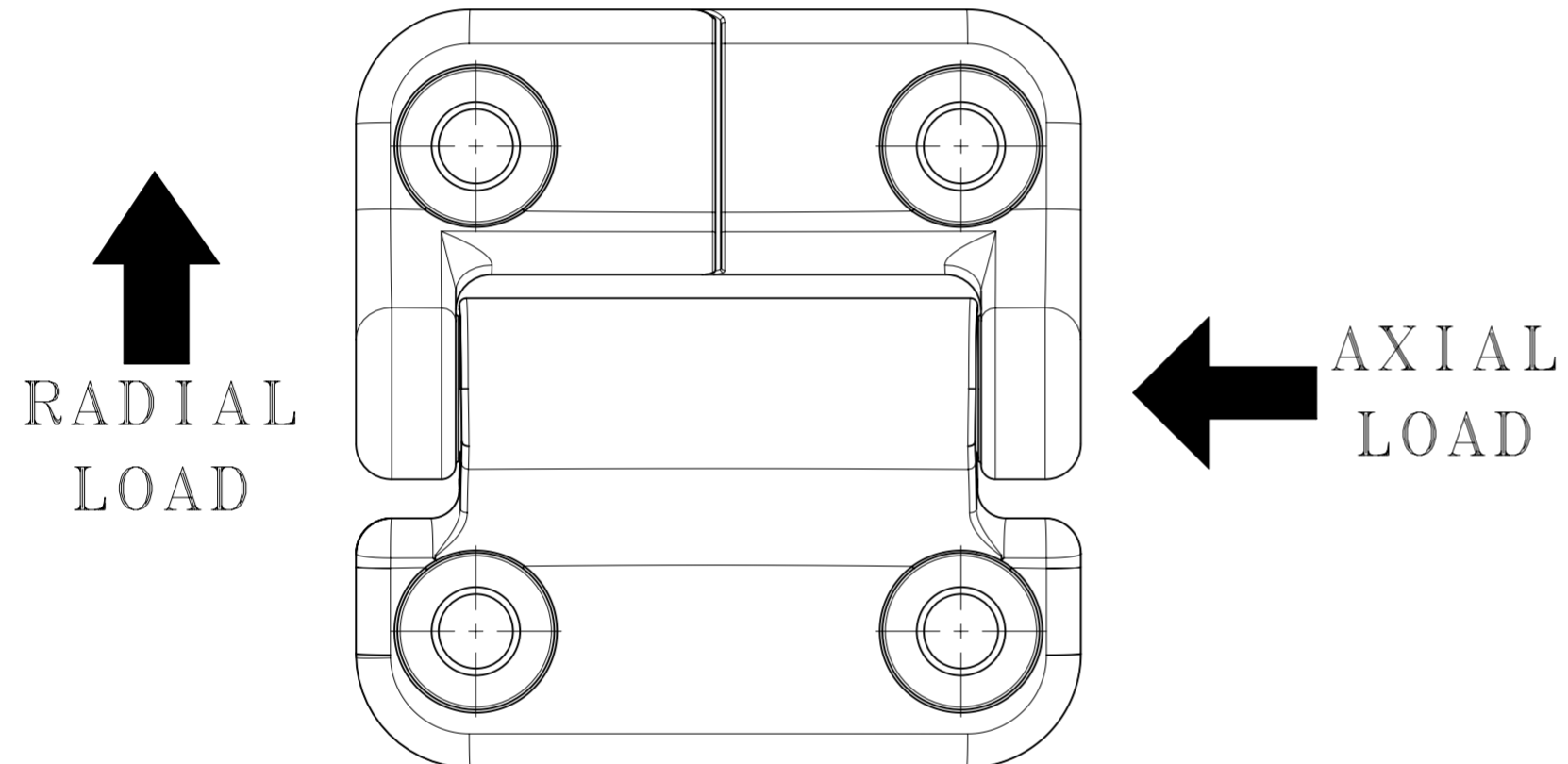

CYCLE TEST SETUP

SCALE 1:2

TYPICAL TORQUE TREND FOR E6-7X-4XXX-XX (REFERENCE ONLY)

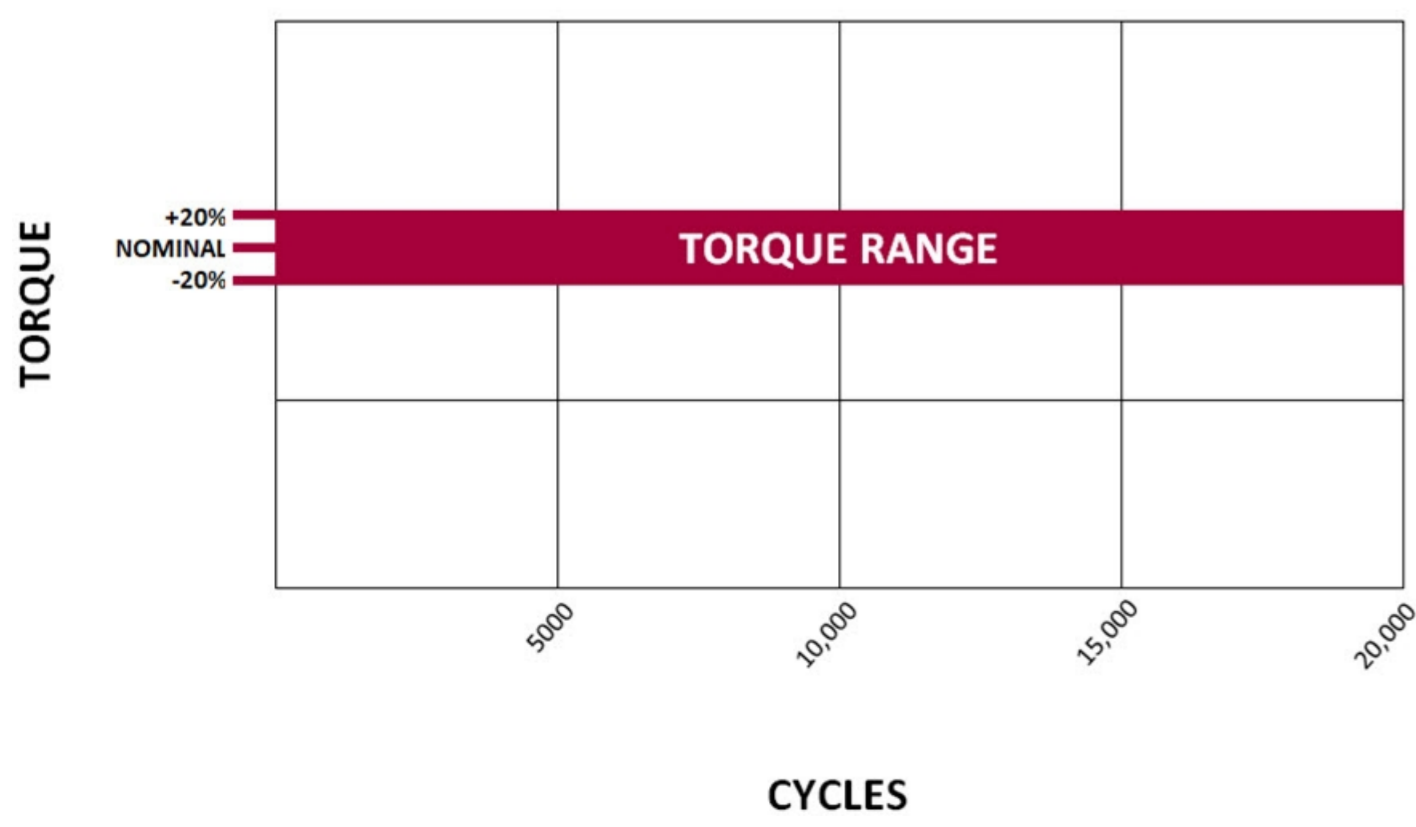

- NOTES:
- ONE CYCLE = CLOSED POSITION TO OPEN POSITION AT 180° PLUS RETURN TO INITIAL CLOSED POSITION
 - TORQUE SPECIFICATIONS AT A CYCLE LIFE OF 20,000
 - PERFORMANCE TORQUE TOLERANCE: ±20% OVER 20,000 CYCLES
 - CYCLE TESTING WAS CONDUCTED USING THE FOLLOWING PROFILE WITH A 2.27 kg (5.0 lbf) TEST PANEL:
 - 5,000 CYCLES AT -20° C
 - 10,000 CYCLES AT AMBIENT
 - 5,000 CYCLES AT 65° C
 - FOR TEST REPORTS SEE trE6-46155, trE6-49363, trE6-52523

THIRD ANGLE PROJECTION		southco CONNECT · CREATE · INNOVATE
MILLIMETERS [IN]		
TOLERANCES UNLESS OTHERWISE NOTED		DESCRIPTION HINGE & CONTROLLED MOTION DEVICE, COUNTERBORED
UP TO 0.5	±0.05	
OVER 0.5 UP TO 6	±0.1	
OVER 6 UP TO 30	±0.2	
OVER 30	±0.3	
ANGLES	±1°	
PROPRIETARY ITEM EXCEPT FOR USES EXPRESSLY GRANTED IN WRITING. INFORMATION DISCLOSED HEREON IS CONFIDENTIAL AND ALL RIGHTS, PATENT AND OTHERWISE, ARE RESERVED BY SOUTHCO, INC.	PER ASME Y14.5M-1994	SIZE SYSTEM A2 NX
DRAWN BY AJD		DWG NO. TD-E6-70-400
DATE 21JUN2021		SCALE 2:1
SHEET 1 OF 1		