

REVISION HISTORY			
REV	DATE	BY	DESCRIPTION
A	10JUN2022	VK/YGC	PRN: P2022-1089

**SOUTHCO PERFORMANCE GUIDELINES**

THE PERFORMANCE GUIDELINES SHOWN ON THIS PAGE ARE SUPPLIED AS A GENERAL GUIDE ONLY. AS CONDITIONS VARY WITH EACH APPLICATION AND METHOD OF INSTALLATION. STRENGTH DATA GIVEN IS FOR FAILURE OF THE PRODUCT OR FOR SUFFICIENT DEFORMATION TO MAKE THE PRODUCT INOPERABLE. NO SAFETY FACTOR HAS BEEN APPLIED. IT IS RECOMMENDED THAT THE USER REQUEST A PRODUCT SAMPLE FOR TESTING TO DETERMINE THE SUITABILITY OF THE PRODUCT FOR THE PURPOSE INTENDED AND USER'S PARTICULAR APPLICATION

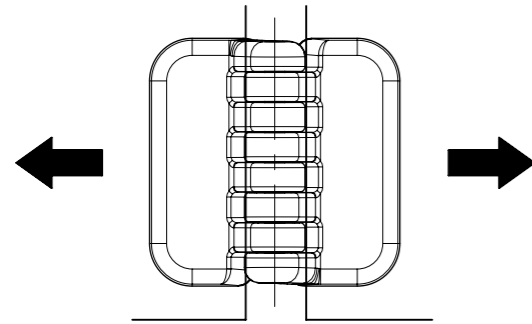

RADIAL IN-LINE

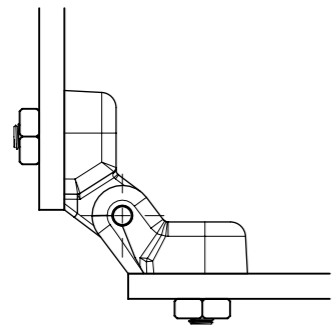

RADIAL @ 90°

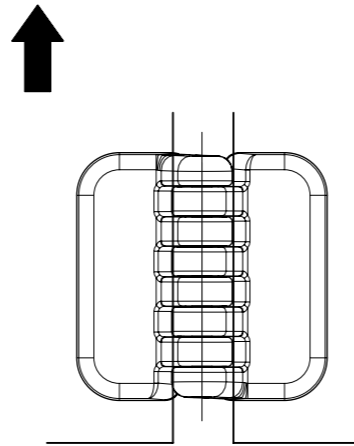

AXIAL

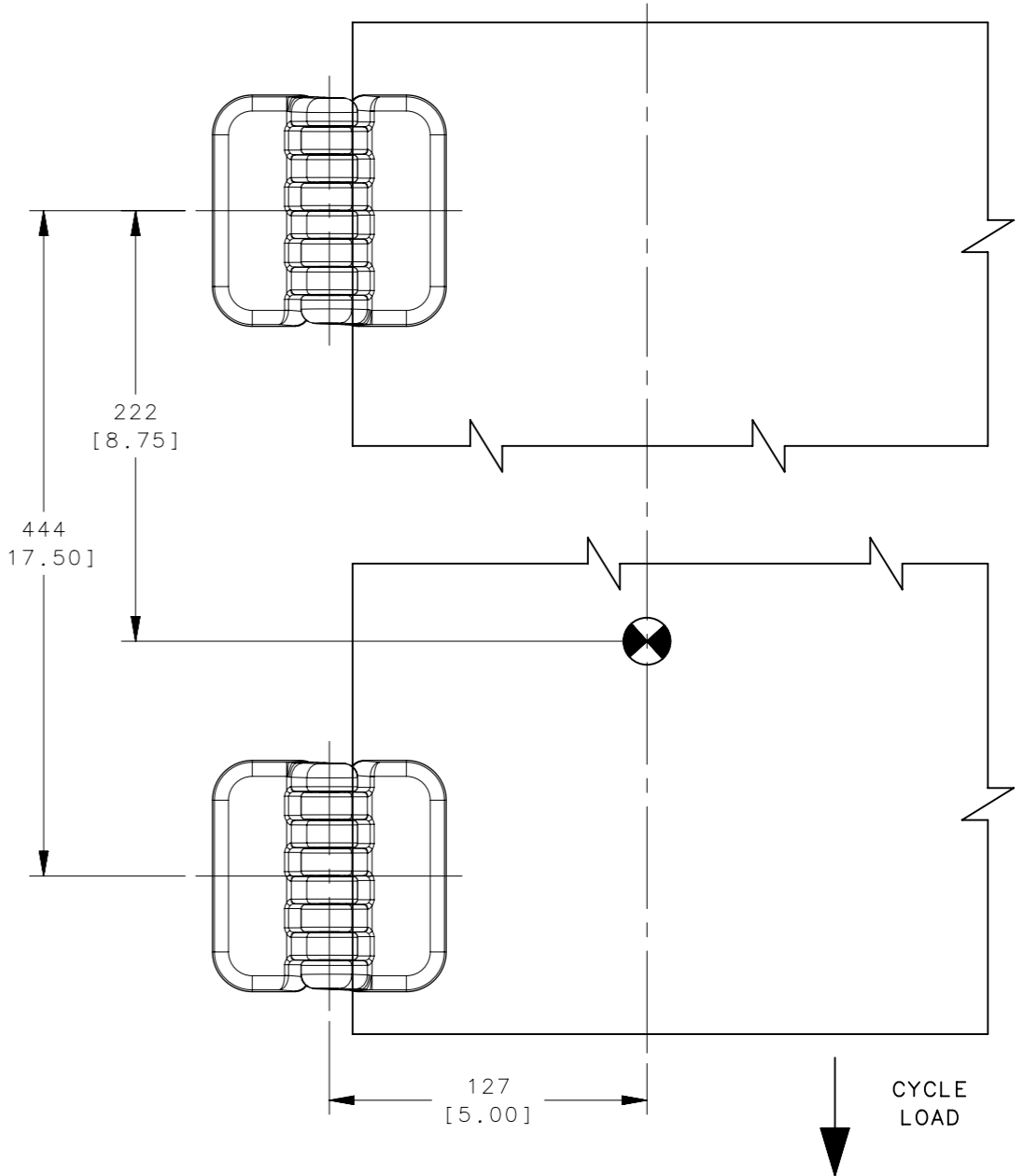

CYCLE TEST SET-UP

PART NO. SHOWN: EH-12B-10G10-20

PART NUMBER	CYCLE LIFE • 178N/ 40lbf	MAX AXIAL LOAD				MAX RADIAL IN-LINE LOAD				MAX RADIAL LOAD @ 90°				RECOMMENDED TIGHTENING TORQUE OF SCREW/NUT			
		ULTIMATE LOAD		WORKING LOAD		ULTIMATE LOAD		WORKING LOAD		ULTIMATE LOAD		WORKING LOAD		SCREW		SCREW/NUT	
		N	lbf	N	lbf	N	lbf	N	lbf	N	lbf	N	lbf	N-m	lbf-in	N-m	lbf-in
		EH-12B-10V10-20	5,000 CYCLES	8150	1832	1110	250	14500	3260	1230	277	7100	1596	510	115	5	44.25
EH-12B-10W10-20	11200	2518		1050	236	13670	3073	2060	463	6610	1486	540	121	5	44.25	-	-
EH-12B-10T10-20	12000	2698		970	218	17200	3867	2120	477	5970	1342	590	133	5	44.25	-	-
EH-12B-10G10-20	9370	2106		890	200	12400	2788	1730	389	6600	1484	460	103	-	-	5	44.25
EH-12B-10GT10-20	9370	2106		890	200	12400	2788	1730	389	5970	1342	590	133	5	44.25	5	44.25
EH-12B-10GW10-20	9370	2106		890	200	12400	2788	1730	389	6600	1484	540	121	5	44.25	5	44.25
EH-12B-10GV10-20	8150	1832		890	200	12400	2788	1230	277	6600	1484	540	121	5	44.25	5	44.25
EH-12B-10TW10-20	11200	2518		970	218	13670	3073	2060	463	5970	1342	590	133	5	44.25	5	44.25
EH-12B-10TV10-20	8150	1832		970	218	14500	3260	1230	277	5970	1342	590	133	5	44.25	5	44.25

NOTE:

1. TWO HINGES WERE MOUNTED ON A 40lb. CABINET DOOR, SAMPLES WERE ROTATED(CYCLED) 180°. PRODUCT PASSED 5,000 CYCLES WITH NO LOSS OF FUNCTION.

REF: trEH-48611, trEH-48612, trEH-48613, trEH-48634, trEH-48635, trEH-48636, trEH-48637, trEH-48661, trEH-48662, trEH-48663, trEH-48664, trEH-48670, trEH-48671, trEH-48672, trEH-48673, trEH-47440.

CPB NUMBER 2019-0813	THIRD ANGLE PROJECTION	<b>southco</b> <sup>®</sup> CONNECT • CREATE • INNOVATE
SURFACE AREA	MILLIMETERS [IN]	
VOLUME	TOLERANCES UNLESS OTHERWISE NOTED	DESCRIPTION FREE SWINGING HINGE ASSEMBLY 100MM VARIANT
PROPRIETARY ITEM EXCEPT FOR USES EXPRESSLY GRANTED IN WRITING, INFORMATION DISCLOSED HEREON IS CONFIDENTIAL AND ALL RIGHTS, PATENT AND OTHERWISE, ARE RESERVED BY SOUTHCO, INC.	PER ASME Y14.5M-1994	SIZE SYSTEM A3 NX
		DWG NO. TD-EH-12B-10-20
		DRAWN BY VK
		DATE 10FEB2020
		SCALE 1:3
		SHEET 1 OF 1