

REVISION HISTORY			
REV	DATE	BY	DESCRIPTION
A	10JUN2022	VK/YGC	PRN: P2022-1089

SOUTHCO PERFORMANCE GUIDELINES

THE PERFORMANCE GUIDELINES SHOWN ON THIS PAGE ARE SUPPLIED AS A GENERAL GUIDE ONLY. AS CONDITIONS VARY WITH EACH APPLICATION AND METHOD OF INSTALLATION. STRENGTH DATA GIVEN IS FOR FAILURE OF THE PRODUCT OR FOR SUFFICIENT DEFORMATION TO MAKE THE PRODUCT INOPERABLE. NO SAFETY FACTOR HAS BEEN APPLIED. IT IS RECOMMENDED THAT THE USER REQUEST A PRODUCT SAMPLE FOR TESTING TO DETERMINE THE SUITABILITY OF THE PRODUCT FOR THE PURPOSE INTENDED AND USER'S PARTICULAR APPLICATION

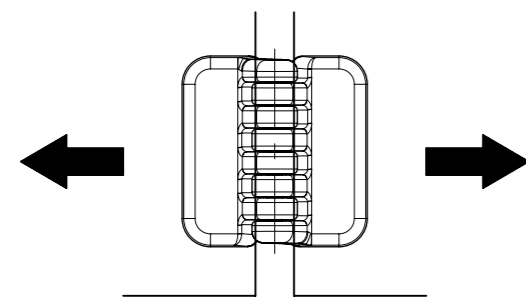

RADIAL IN-LINE

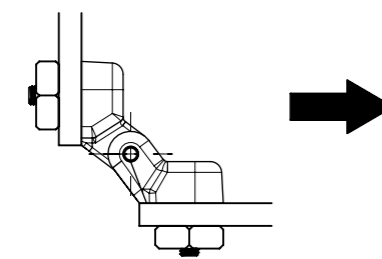

RADIAL @ 90°

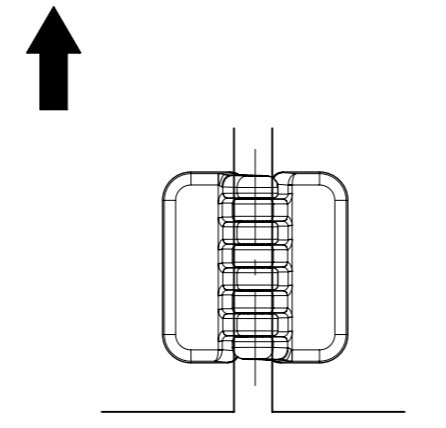

AXIAL

PART NO. SHOWN: EH-6B-5G5-20

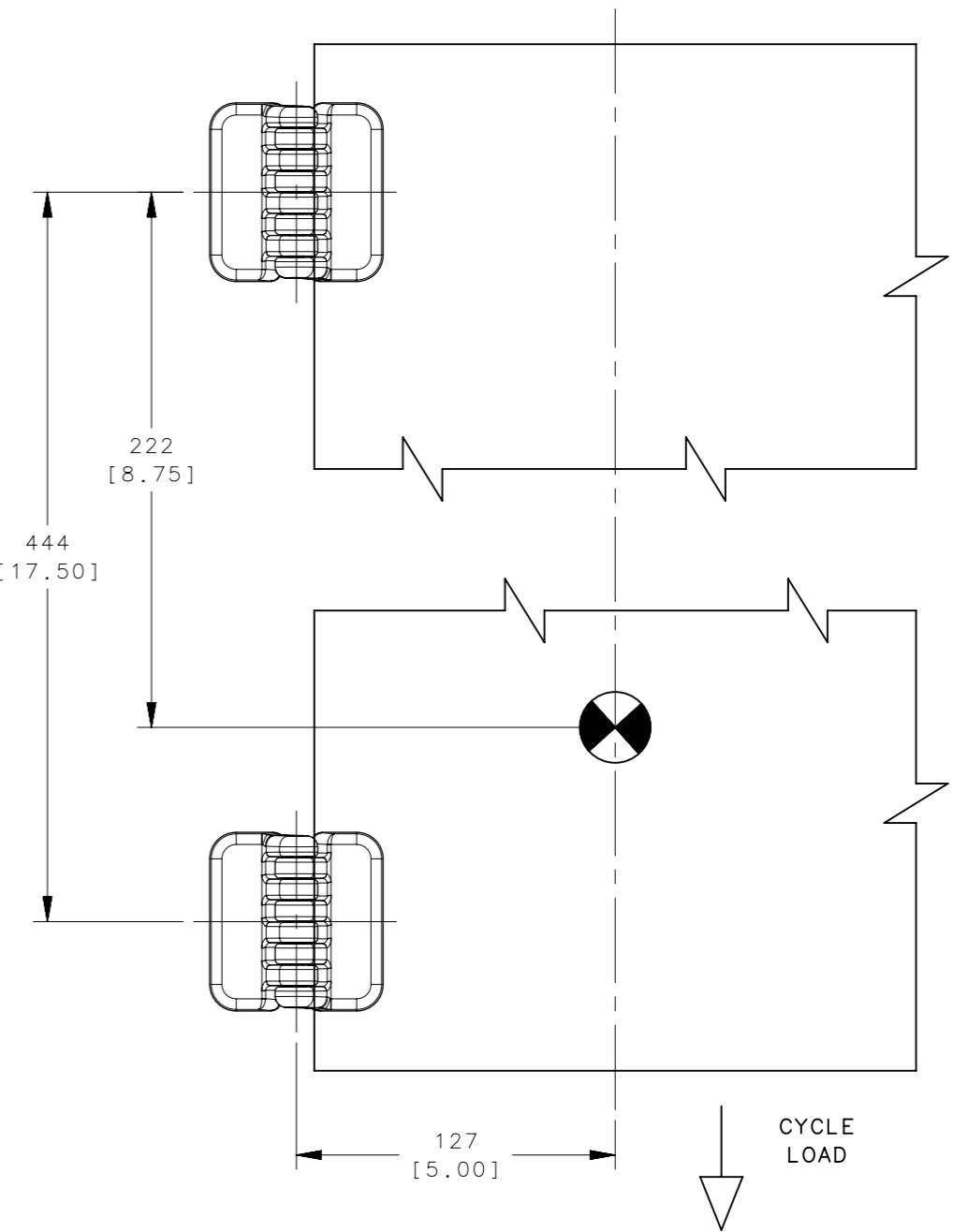

CYCLE TEST SET-UP

PART NUMBER	CYCLE LIFE ● 89N/ 20lbf	MAX AXIAL LOAD				MAX RADIAL IN-LINE LOAD				MAX RADIAL LOAD ● 90°				RECOMMENDED TIGHTENING TORQUE OF SCREW/NUT			
		ULTIMATE LOAD		WORKING LOAD		ULTIMATE LOAD		WORKING LOAD		ULTIMATE LOAD		WORKING LOAD		SCREW		SCREW/NUT	
		N	lbf	N	lbf	N	lbf	N	lbf	N	lbf	N	lbf	N-m	lbf-in	N-m	lbf-in
		EH-6B-5V5-20	5,000 CYCLES	4140	931	300	67	4550	1023	310	70	2490	560	320	72	2	17.7
EH-6B-5W5-20	3440	773		360	81	4590	1032	310	70	2520	566	250	56	2	17.7	-	-
EH-6B-5T5-20	3530	794		400	90	3070	690	440	99	1470	330	170	38	5	44.25	-	-
EH-6B-5G5-20	3600	809		370	83	3510	789	360	81	2450	551	200	45	-	-	5	44.25
EH-6B-5GT5-20	3530	794		370	83	3070	690	360	81	1470	330	170	38	5	44.25	5	44.25
EH-6B-5GW5-20	3440	773		360	81	3510	789	310	70	2450	551	200	45	2	17.7	5	44.25
EH-6B-5GV5-20	3600	809		300	67	3510	789	310	70	2450	551	200	45	2	17.7	5	44.25
EH-6B-5TW5-20	3440	773		360	81	3070	690	310	70	1470	330	170	38	5	44.25	2	17.7
EH-6B-5TV5-20	3530	794		300	67	3070	690	310	70	1470	330	170	38	5	44.25	2	17.7

NOTE:
1. TWO HINGES WERE MOUNTED ON A 20lb. CABINET DOOR, SAMPLES WERE ROTATED(CYCLED) 180°. PRODUCT PASSED 5,000 CYCLES WITH NO LOSS OF FUNCTION.

REF: trEH-47458, trEH-48828, trEH-47460, trEH-48829, trEH-46850, trEH-46851, trEH-46852, trEH-46853, trEH-47442, trEH-47443, trEH-47444, trEH-47445, trEH-47448, trEH-47449, trEH-47451, trEH-47455, trEH-47457, trEH-47459.

CPB NUMBER 2019-0813	THIRD ANGLE PROJECTION	southco [®] CONNECT • CREATE • INNOVATE
SURFACE AREA	MILLIMETERS [IN]	
VOLUME	TOLERANCES UNLESS OTHERWISE NOTED	DESCRIPTION FREE SWINGING HINGE ASSEMBLY 50MM VARIANT
PROPRIETARY ITEM EXCEPT FOR USES EXPRESSLY GRANTED IN WRITING, INFORMATION DISCLOSED HEREON IS CONFIDENTIAL AND ALL RIGHTS, PATENT AND OTHERWISE, ARE RESERVED BY SOUTHCO, INC.	PER ASME Y14.5M-1994	SIZE A3 SYSTEM NX DWG NO. TD-EH-6B-5-20
		DRAWN BY VK DATE 19FEB2020 SCALE 1:2 SHEET 1 OF 1