

REVISION HISTORY			
REV	DATE	BY	DESCRIPTION
A	03FEB2021	MBT/DMS	PRN: P2021-0245

SOUTHCO PERFORMANCE GUIDELINES

THE PERFORMANCE GUIDELINES SHOWN ON THIS PAGE ARE SUPPLIED AS A GENERAL GUIDE ONLY, AS CONDITIONS VARY WITH EACH APPLICATION AND METHOD OF INSTALLATION. STRENGTH DATA GIVEN IS FOR FAILURE OF THE PRODUCT OR FOR SUFFICIENT DEFORMATION TO MAKE THE PRODUCT INOPERABLE. NO SAFETY FACTOR HAS BEEN APPLIED. IT IS RECOMMENDED THAT THE USER REQUEST A PRODUCT SAMPLE FOR TESTING TO DETERMINE THE SUITABILITY OF THE PRODUCT FOR THE PURPOSE INTENDED AND USER'S PARTICULAR APPLICATION.

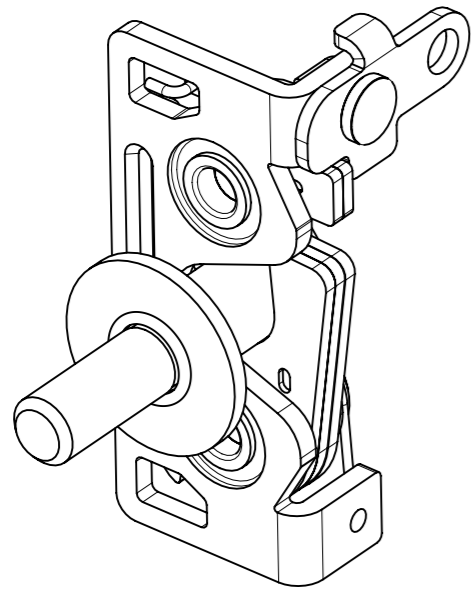

PERPENDICULAR ACTUATION

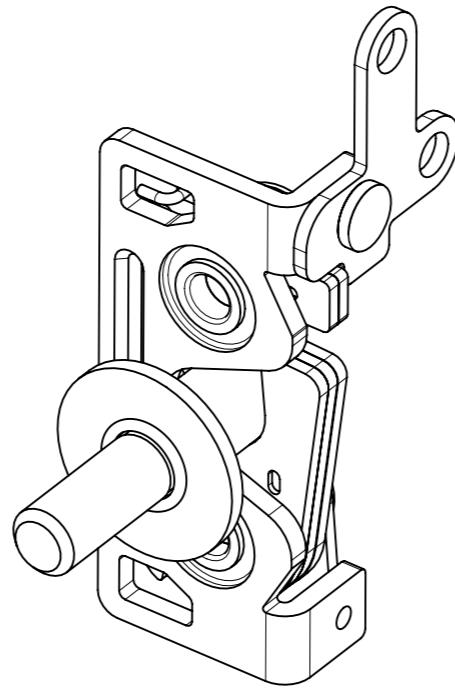

2-POINT ACTUATION

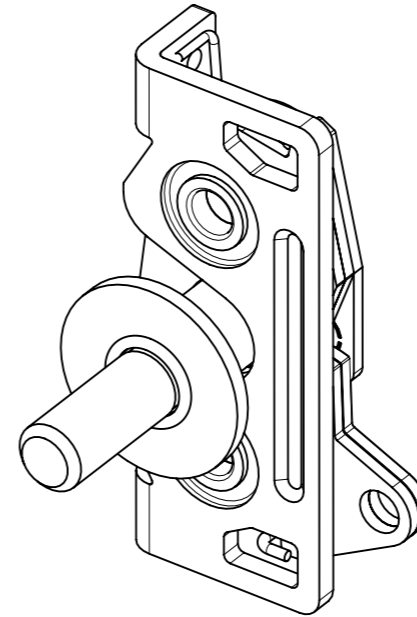

BOTTOM ACTUATION

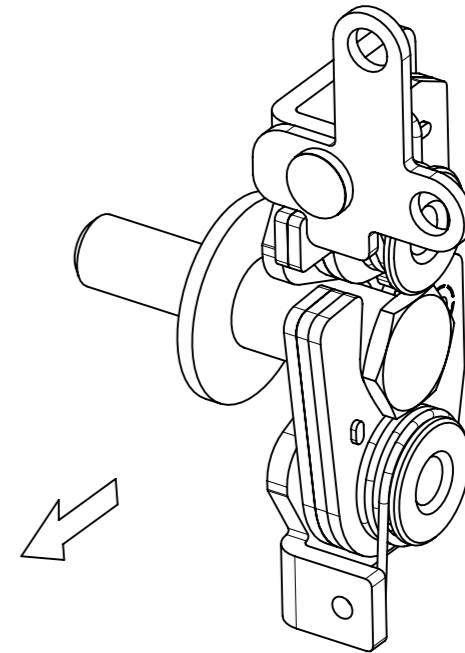

DIRECTION OF TRANSVERSE LOAD AND GASKET FORCE

PERFORMANCE VALUES FOR PART NUMBERS R4-30-10-501-10 AND R4-30-20-501-10.

GASKET FORCE	AVERAGE FORCE REQUIRED TO ACTUATE (OPEN) LATCH	AVERAGE TRANSVERSE TENSILE FORCE BEFORE LATCH FRACTURE OR STRIKER PULL-OUT	CYCLE LIFE
200 n (45 lb)	57.8 N (13 lbf)	10000 N (2248 lbf)	60,000

REF: trR4-42191

THIRD ANGLE PROJECTION		southco [®] CONNECT • CREATE • INNOVATE	
MILLIMETERS [IN]			
TOLERANCES UNLESS OTHERWISE NOTED		DESCRIPTION R4-30 SINGLE STAGE ROTARY LATCH, STEEL	
ALL DIMENSIONS WITHOUT TOLERANCES ARE FOR REFERENCE ONLY.		SIZE A3	SYSTEM NX
PROPRIETARY ITEM <small>EXCEPT FOR USES EXPRESSLY GRANTED IN WRITING, INFORMATION DISCLOSED HEREON IS CONFIDENTIAL AND ALL RIGHTS, PATENT AND OTHERWISE, ARE RESERVED BY SOUTHCO, INC.</small>		DWG NO. TD-R4-2-1-J	DATE 03FEB2021
PER ASME Y14.5M-1994		DRAWN BY MBT/DMS	SCALE NTS
		SHEET 1 OF 1	