

REVISION HISTORY			
REV	DATE	BY	DESCRIPTION
B	22SEP2014	DJK/GGG	PRN: P2014-1873

SOUTHCO PERFORMANCE GUIDELINES

THE PERFORMANCE GUIDELINES SHOWN ON THIS PAGE ARE SUPPLIED AS A GENERAL GUIDE ONLY, AS CONDITIONS VARY WITH EACH APPLICATION AND METHOD OF INSTALLATION. STRENGTH DATA GIVEN IS FOR FAILURE OF THE PRODUCT OR FOR SUFFICIENT DEFORMATION TO MAKE THE PRODUCT INOPERABLE. NO SAFETY FACTOR HAS BEEN APPLIED. IT'S RECOMMENDED THAT THE USER REQUEST A PRODUCT SAMPLE FOR TESTING TO DETERMINE THE SUITABILITY OF THE PRODUCT FOR THE PURPOSE INTENDED AND THE USER'S PARTICULAR APPLICATION.

PERFORMANCE VALUES FOR R4-EM-8X-X30 AND R4-EM-8X6-X30
SEE J-R4-EM-8-1

- TESTING PERFORMED ON R4-EM-8X-XX0 AND R4-EM-8X6-XX0.
- TENSILE FORCES (DIRECTION 1) ARE APPLIED AT THE NOMINAL LATERAL POSITION (ZERO MISALIGNMENT).
- CYCLE LIFE WITH 44 N (10 lbf) TENSILE FORCE (DIRECTION 1) ON CAM : 100,000 CYCLES
CYCLE TEMPERATURE PROFILE: 80,000 AT AMBIENT TEMP, 10,000 AT -20C, 10,000 AT +60C
- MAXIMUM TENSILE FORCE (DIRECTION 1) ON THE CAM THAT THE LATCH CAN RELEASE (OPEN) ELECTRICALLY ONE TIME:
225 N (50 lbf) MINIMUM FOR 12VOLT MODELS
550 N (124 lbf) MINIMUM FOR 24VOLT MODELS
- AVERAGE ULTIMATE TENSILE LOAD (DIRECTION 1) ON THE CAM BEFORE LATCH CAM FAILURE: 5300 N (1191 lbf).
- AVERAGE ULTIMATE TENSILE LOAD (DIRECTION 1) WHEN USED WITH SOUTHCO STRIKER BOLT R4-90-121-10: 5200 N (1169 lbf)
- AVERAGE TENSILE FORCE (DIRECTION 2) REQUIRED ON THE MECHANICAL OVERRIDE TRIGGER TO OPERATE (OPEN) THE LATCH MANUALLY WITH A TENSILE FORCE ON THE CAM:

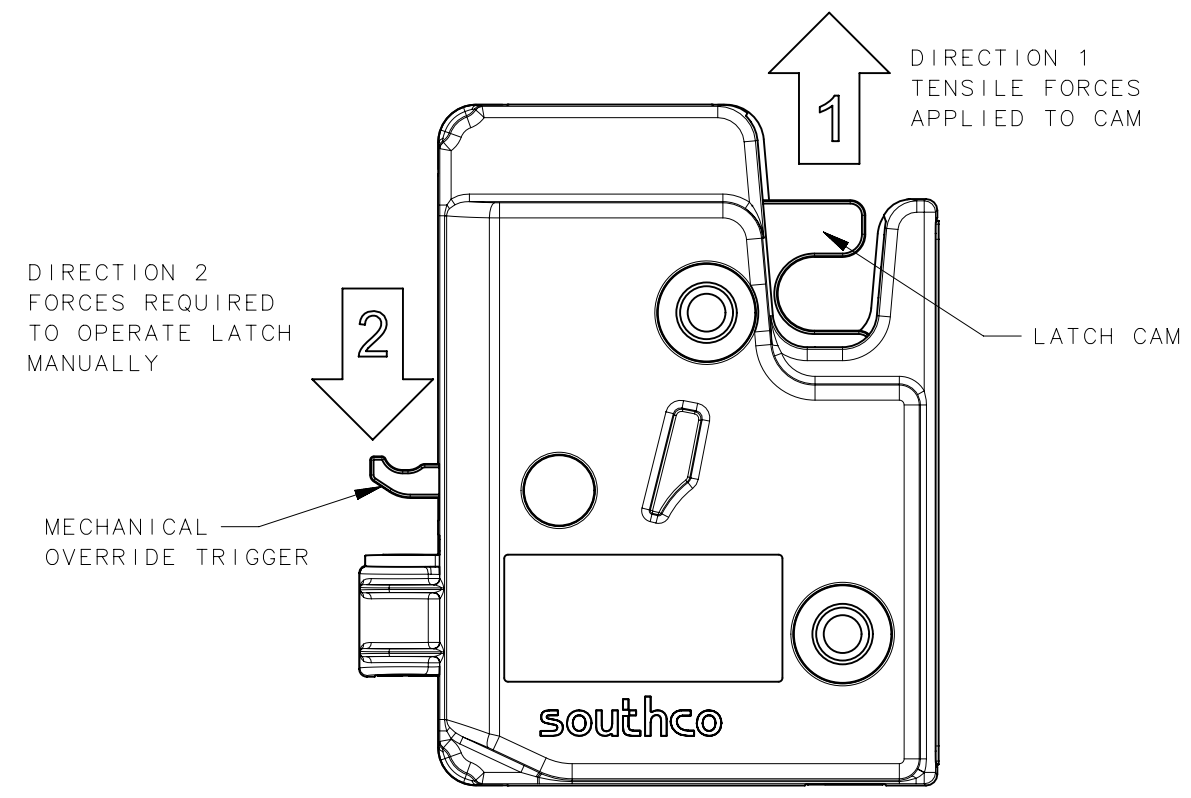

R4-EM-8X6-X30 SHOWN

AVERAGE FORCE TO OPERATE LATCH WITH MECHANICAL OVERRIDE VS. LATCH CAM LOAD					
FORCE 1 (N) ON CAM	100 N (22.48 lbf)	200 N (44.96 lbf)	300 N (67.44 lbf)	400 N (89.92 lbf)	500 N (112.40 lbf)
FORCE 2 (N) ON MECHANICAL OVERRIDE	11.8 N (2.65 lbf)	17.7 N (3.98 lbf)	23.1 N (5.19 lbf)	29.5 N (6.63 lbf)	33.3 N (7.49 lbf)

8. OPERATING TEMPERATURE RANGE -20 TO 60°C.

REF: trR4-16556, trR4-19223
trR4-17650, trR4-18904

THIRD ANGLE PROJECTION				 CONNECT • CREATE • INNOVATE	
MILLIMETERS [IN]					
SURFACE AREA		TOLERANCES UNLESS OTHERWISE NOTED		DESCRIPTION R4-EM 8 SERIES ELECTROMECHANICAL ROTARY LATCH	
VOLUME		UP TO 0.5 ±0.05 OVER 0.5 UP TO 6 ±0.1 OVER 6 UP TO 30 ±0.2 OVER 30 ±0.3 ANGLES ±1°			
PROPRIETARY ITEM		SIZE	SYSTEM	DWG NO.	
EXCEPT FOR USES EXPRESSLY GRANTED IN WRITING, INFORMATION DISCLOSED HEREON IS CONFIDENTIAL AND ALL RIGHTS, PATENT AND OTHERWISE, ARE RESERVED BY SOUTHCO, INC.		A3	NX	TD-R4-EM-8-1-J	
PER ASME Y14.5M-1994		DRAWN BY	DATE	SCALE	SHEET
		DJK/GGG	27JAN2014	1:1	1 OF 1