

REVISION HISTORY			
REV	DATE	BY	DESCRIPTION
A	22APR2024	GEA/	PRN: P2024-0632

SOUTHCO PERFORMANCE GUIDELINES:
 THE PERFORMANCE GUIDELINES SHOWN ON THIS DRAWING ARE SUPPLIED AS A GENERAL GUIDE ONLY, AS CONDITIONS VARY WITHIN EACH APPLICATION AND METHOD OF INSTALLATION. STRENGTH DATA GIVEN IS FOR FAILURE OF THE PRODUCT OR FOR SUFFICIENT DEFORMATION TO MAKE THE PRODUCT INOPERABLE. NO SAFETY FACTOR HAS BEEN APPLIED. IT IS RECOMMENDED THAT THE USER REQUEST A PRODUCT SAMPLE FOR TESTING TO DETERMINE THE SUITABILITY OF THE PRODUCT FOR THE PURPOSE INTENDED AND THE USER'S PARTICULAR APPLICATION.

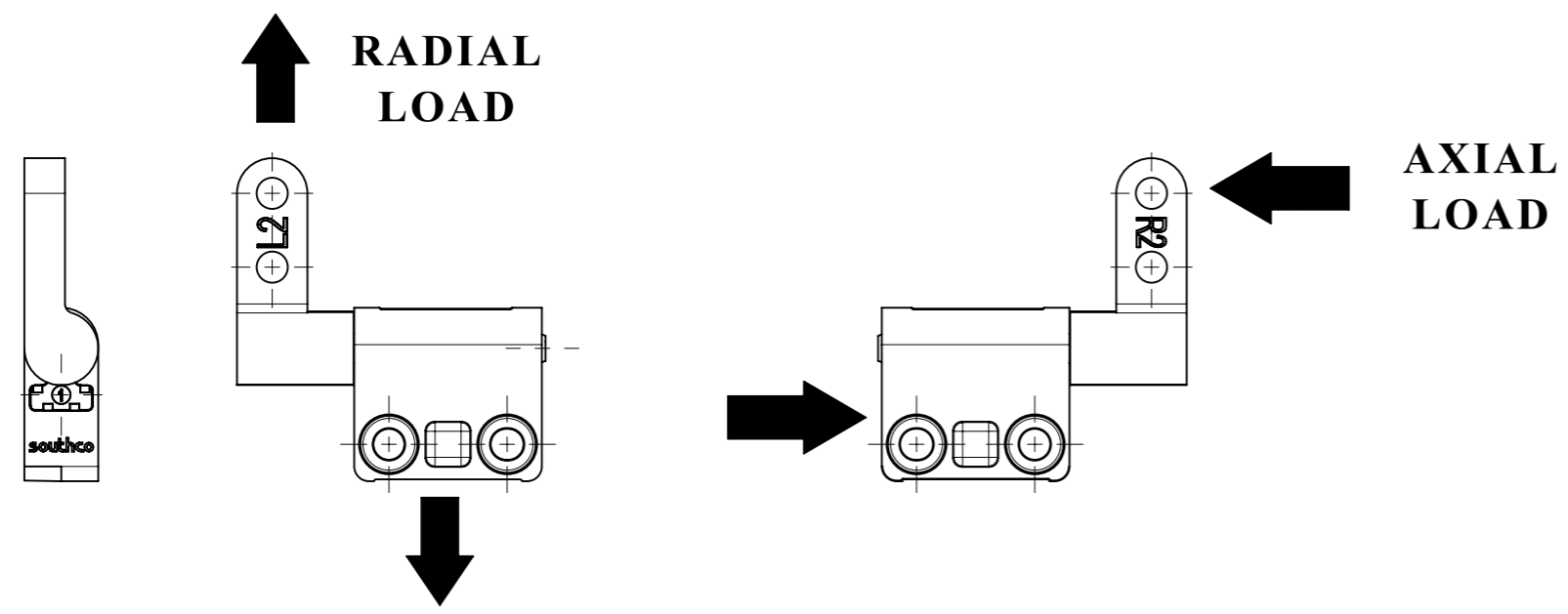

PART NUMBERS	AVERAGE ULTIMATE STATIC LOAD		CYCLE LIFE (Note 1, Note 2)
	RADIAL LOAD N / lb *	AXIAL LOAD N / lb **	
TYPE A & B			
ST-10A2-XXYA-ZZ	2300 / 517	2400 / 540	30,000 ***
ST-10A2-XXYB-ZZ			
TYPE T			
ST-10A2-XXYT-ZZ	2300 / 517	2400 / 540	50,000 ****
TYPE W			
ST-10A2-XXYW-ZZ	2300 / 517	2400 / 540	

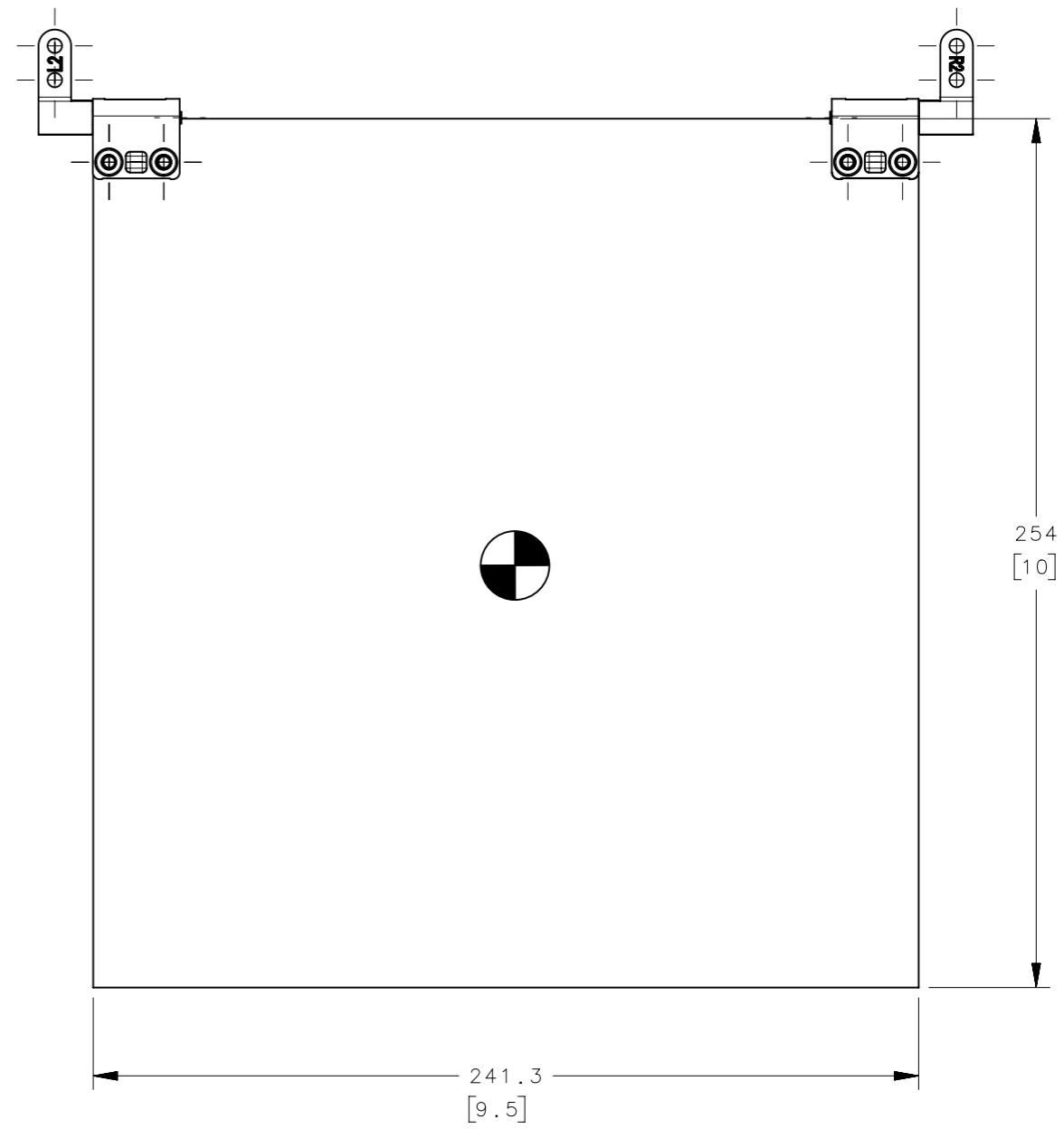

**CYCLE TEST SET-UP
(HORIZONTAL HINGE AXIS)**

- NOTES:
1. AXIAL LOAD OF 1000N (224.8 lbf) AND RADIAL LOAD OF 500N (112.4 lbf) APPLIED ONE TIME TO HINGES WITHOUT DEGRADATION OF COMPONENTS BEFORE CYCLE TESTING HINGES.
 2. HINGE CYCLE TEST IS CLOSED POSITION TO OPEN POSITION AT 180° PLUS RETURN TO INITIAL CLOSED POSITION AT AMBIENT TEMPERATURE USING A1.34 kg (2.94 lbf) OR EQUIVALENT WEIGHT/ CG MOMENT TEST DOOR AT A CYCLE RATE OF 5 CYCLES PER MINUTE.
 3. XX IS THE HINGE TORQUE SPECIFICATION
 4. Y IS THE HINGE TORQUE TYPE DESIGNATION
 5. -ZZ SUFFIX IS HINGE FINISH DESIGNATION:
 33 - NATURAL ZINC
 50 - BLACK POWDER COATING
 53 - BLACK ZINC PLATING
 6. SOUTHCO PRODUCT TESTING REPORTS USED FOR GENERATING THIS PRODUCT DATA:
 * trST-1279005
 ** trST-1304033
 *** trST-1104101
 **** trST-1697898

DRAFT NOT FOR CUSTOMER USE

CPB NUMBER 2021-0920	THIRD ANGLE PROJECTION	southco CONNECT • CREATE • INNOVATE		
	MILLIMETERS [IN]			
SURFACE AREA XXXXXmm ²	TOLERANCES UNLESS OTHERWISE NOTED UP TO 0.5 ±0.05 OVER 0.5 UP TO 6 ±0.1 OVER 6 UP TO 30 ±0.2 OVER 30 ±0.3 ANGLES ±1°	DESCRIPTION HINGE & CONTROLLED MOTION DEVICE ST-10A2 HINGE, TYPE A, B, T and W		
VOLUME XXXXXmm ³		SIZE A3	SYSTEM NX	DWG NO. TD-ST-10A2-J
PROPRIETARY ITEM		PER ASME Y14.5M-2009	DRAWN BY GEA/	DATE 22APR2024
EXCEPT FOR USES EXPRESSLY GRANTED IN WRITING, INFORMATION DISCLOSED HEREON IS CONFIDENTIAL AND ALL RIGHTS, PATENT AND OTHERWISE, ARE RESERVED BY SOUTHCO, INC.			SCALE 1:1	SHEET 1 OF 1