

REVISION HISTORY			
REV	DATE	BY	DESCRIPTION
B	09NOV2020	JJT/CDW	PRN: P2020-2103

SOUTHCO PERFORMANCE GUIDELINES:
 THE PERFORMANCE GUIDELINES SHOWN ON THIS PAGE ARE SUPPLIED AS A GENERAL GUIDE ONLY, AS CONDITIONS VARY WITH EACH APPLICATION AND METHOD OF INSTALLATION, STRENGTH DATA GIVEN IS FOR FAILURE OF THE PRODUCT OR FOR SUFFICIENT DEFORMATION TO MAKE THE PRODUCT INOPERABLE. NO SAFETY FACTOR HAS BEEN APPLIED IT IS RECOMMENDED THAT THE USER REQUEST A PRODUCT SAMPLE FOR TESTING TO DETERMINE THE SUITABILITY OF THE PRODUCT FOR THE PURPOSE INTENDED AND USER'S PARTICULAR APPLICATION.

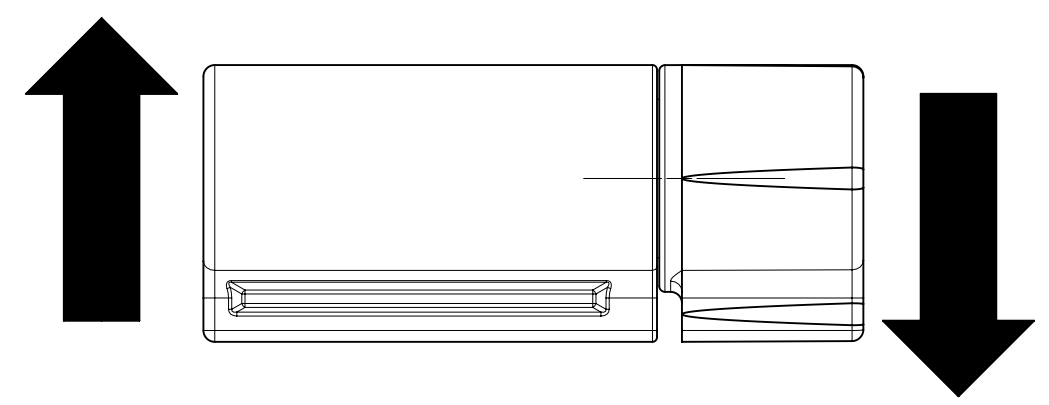
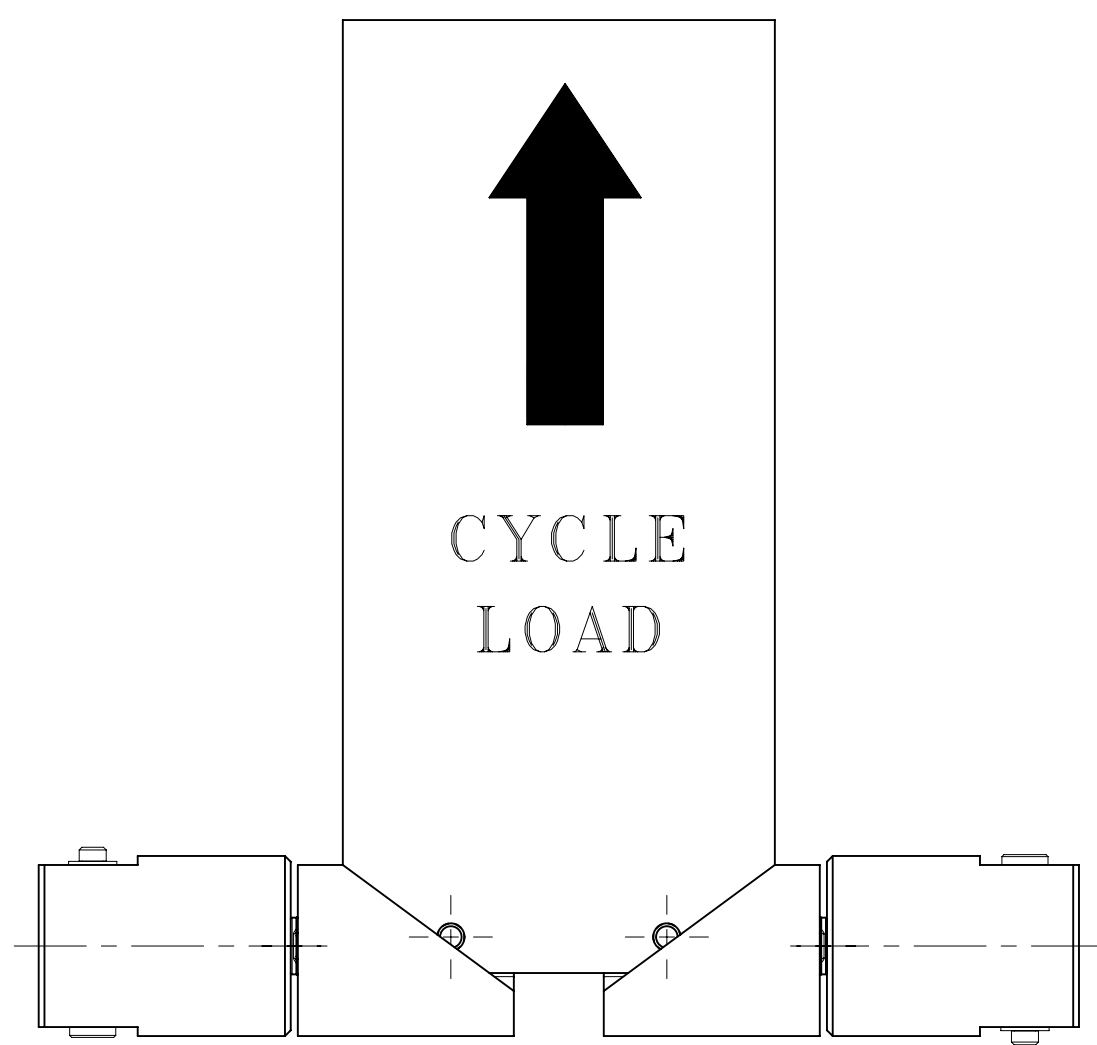

RADIAL
LOAD

PART NUMBER	RADIAL LOAD N (lbf)	STATIC TORQUE		CYCLE LIFE	
		FORWARD TORQUE Nm (in-lbf)	REVERSE TORQUE Nm (in-lbf)		
ST-10P-140S-33	334 (75)	1.58 (14)		20,000	
ST-10P-100S-33		1.13 (10)			
ST-10P-080S-33		0.90 (8)			
ST-10P-040S-33		0.45 (4)			
ST-10P-200F-33		2.26 (20)	1.58 (14) REF		
ST-10P-160F-33		1.81 (16)	1.27 (11.2) REF		
ST-10P-120F-33		1.36 (12)	0.95 (8.4) REF		
ST-10P-080F-33		0.90 (8)	0.63 (5.6) REF		
ST-10P-040F-33		0.45 (4)	0.32 (2.8) REF		
ST-10P-200R-33		1.58 (14) REF	2.26 (20)		
ST-10P-160R-33		1.27 (11.2) REF	1.81 (16)		
ST-10P-120R-33		0.95 (8.4) REF	1.36 (12)		
ST-10P-080R-33		0.63 (5.6) REF	0.90 (8)		
ST-10P-040R-33		0.32 (2.8) REF	0.45 (4)		

- NOTES:
- ONE CYCLE = CLOSED POSITION TO OPEN POSITION AT 180° PLUS RETURN TO INITIAL CLOSED POSITION.
 - CYCLE TESTING CONDUCTED AT AMBIENT.
 - RADIAL LOADS APPLIED ONE TIME TO HINGE WITHOUT DEGRADATION OF PERFORMANCE.
 - FOR TEST REPORTS SEE trST-40175.

CPB NUMBER 2019-0401	THIRD ANGLE PROJECTION	southco [®] CONNECT • CREATE • INNOVATE
	MILLIMETERS [IN]	
	TOLERANCES UNLESS OTHERWISE NOTED	DESCRIPTION HINGE & CONTROLLED MOTION DEVICE
PROPRIETARY ITEM <small>EXCEPT FOR USES EXPRESSLY GRANTED IN WRITING, INFORMATION DISCLOSED HEREON IS CONFIDENTIAL AND ALL RIGHTS, PATENT AND OTHERWISE, ARE RESERVED BY SOUTHCO, INC.</small>	ALL DIMENSIONS WITHOUT TOLERANCES ARE FOR REFERENCE ONLY.	SIZE A3
	PER ASME Y14.5M-1994	SYSTEM NX
		DWG NO. TD-ST-10P-200
		DATE 20JUL2020
		SCALE 1:1
		SHEET 1 OF 1