

6

5

4

3

2

1

SOUTHCO PERFORMANCE GUIDELINES:

THE PERFORMANCE GUIDELINES SHOWN ON THIS DRAWING ARE SUPPLIED AS A GENERAL GUIDE ONLY, AS CONDITIONS VARY WITHIN EACH APPLICATION AND METHOD OF INSTALLATION. STRENGTH DATA GIVEN IS FOR FAILURE OF THE PRODUCT OR FOR SUFFICIENT DEFORMATION TO MAKE THE PRODUCT INOPERABLE. NO SAFETY FACTOR HAS BEEN APPLIED. IT IS RECOMMENDED THAT THE USER REQUEST A PRODUCT SAMPLE FOR TESTING TO DETERMINE THE SUITABILITY OF THE PRODUCT FOR THE PURPOSE INTENDED AND THE USER'S PARTICULAR APPLICATION.

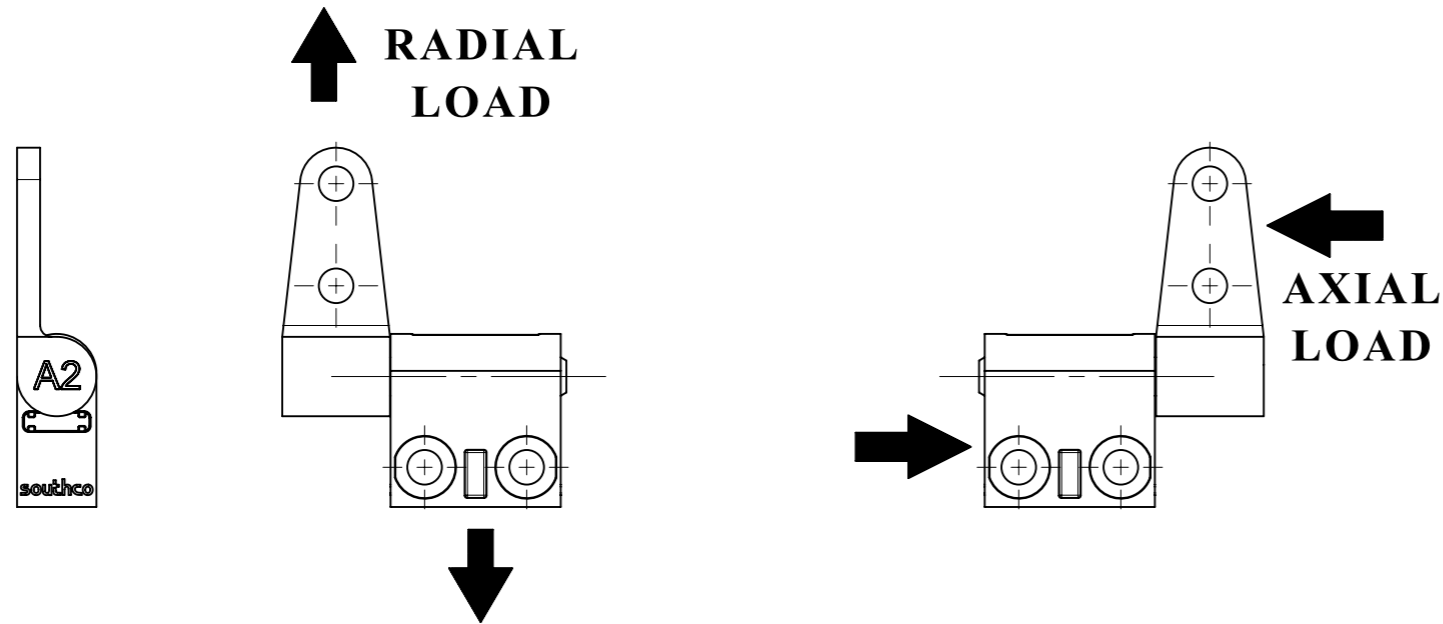

PART NUMBERS	AVERAGE ULTIMATE STATIC LOAD		CYCLE LIFE (Note 1, Note 2)
	RADIAL LOAD * N / lb	AXIAL LOAD ** N / lb	
TYPE A & B			
ST-7A2-XXYA-ZZ	770 / 173	730 / 164	30,000 ***
ST-7A2-XXYB-ZZ			
TYPE T			
ST-7A2-XXYT-ZZ	770 / 173	730 / 164	50,000 ****
ST-7A3-XXYT-ZZ			
TYPE W			
ST-7A3-XXYW-ZZ	770 / 173	730 / 164	

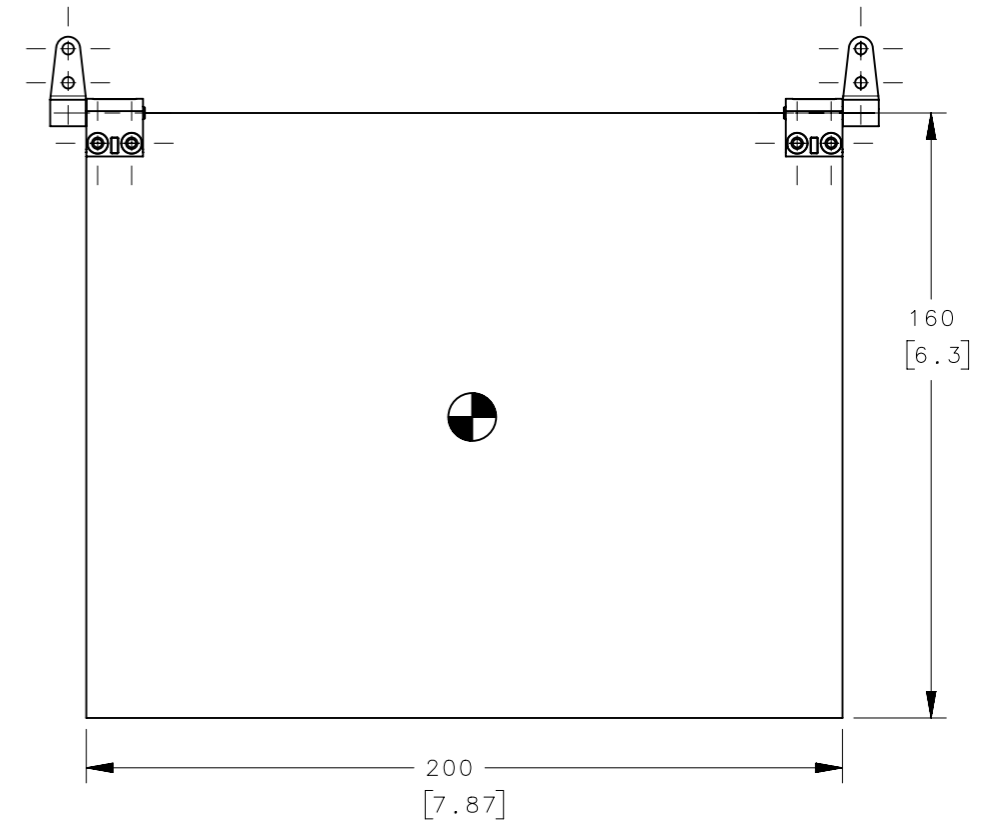

CYCLE TEST SET-UP (HORIZONTAL HINGE AXIS)

NOTES:

- AXIAL LOAD OF 300N (67 lbf) AND RADIAL LOAD OF 400N (90 lbf) APPLIED ONE TIME TO HINGES WITHOUT DEGRADATION OF COMPONENTS BEFORE CYCLE TESTING HINGES.
- HINGE CYCLE TEST IS CLOSED POSITION TO OPEN POSITION AT 180° PLUS RETURN TO INITIAL CLOSED POSITION AT AMBIENT TEMPERATURE USING A 0.54 kg (1.2 lbf) OR EQUIVALENT WEIGHT/ CG MOMENT TEST DOOR AT A CYCLE RATE OF 5 CYCLES PER MINUTE.
- XX IS THE HINGE TORQUE SPECIFICATION
- Y IS THE HINGE TYPE DESIGNATION
- ZZ SUFFIX IS HINGE FINISH DESIGNATION:
 - 33 - NATURAL ZINC
 - 50 - BLACK POWDER COATING
 - 53 - BLACK ZINC PLATING
- SOUTHCO PRODUCT TESTING REPORTS USED FOR GENERATING THIS PRODUCT DATA:
 - * trST-1131307
 - * trST-1813726
 - ** trST-1812727
 - *** trST-1103901
 - **** trST-1133802

CPB NUMBER 2019-0996	THIRD ANGLE PROJECTION	southco [®] CONNECT • CREATE • INNOVATE
	MILLIMETERS [IN]	
SURFACE AREA	TOLERANCES UNLESS OTHERWISE NOTED	DESCRIPTION HINGE & CONTROLLED MOTION DEVICE ST-7A2 HINGE TYPE A AND TYPE B
VOLUME		SIZE SYSTEM A3 NX
PROPRIETARY ITEM EXCEPT FOR USES EXPRESSLY GRANTED IN WRITING, INFORMATION DISCLOSED HEREON IS CONFIDENTIAL AND ALL RIGHTS, PATENT AND OTHERWISE, ARE RESERVED BY SOUTHCO, INC.	PER ASME Y14.5M-2009	DWG NO. TD-ST-7A2-J
	DRAWN BY GEA	DATE 01FEB2022
		SCALE 1:1
		SHEET 1 OF 1

6

5

4

3

2

1