

CN ATCA® Inject / Eject Mechanism

Alignment keying modules

- CN-80 robust design passes the NEBS drop test
- Multiple pin positions ensure proper board mating

Material and Finish

Dual pin CN68 and CN78:

Zinc alloy, nickel plated

Dual pin CN80:

Zinc alloy, hardened steel,

nickel plated

Single pin:

Brass, nickel plated

Notes

Keying module rotation position must mate with receptacle module rotation position

ATCA is a registered trademark of PICMG® - PCI Industrial Computer Manufacturers Group, Inc.

Dual Pin - A1 Backplane - A2 Midplane

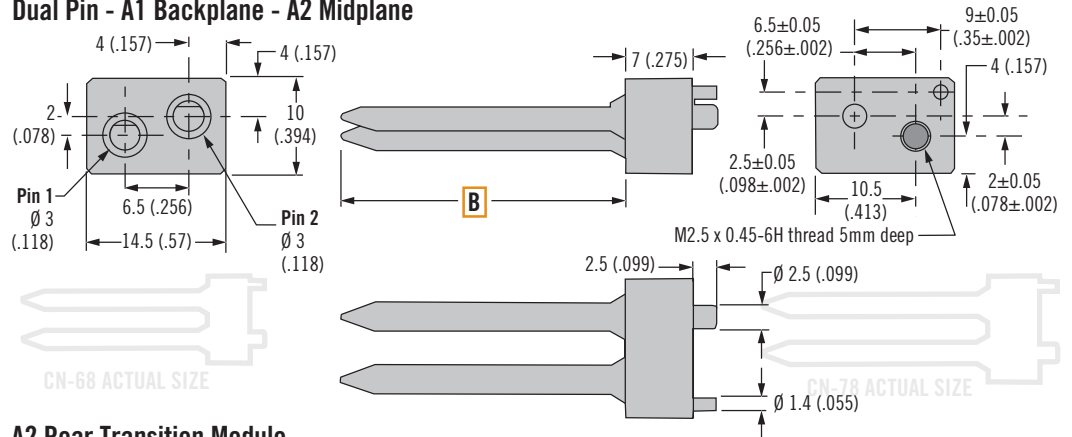

A2 Rear Transition Module

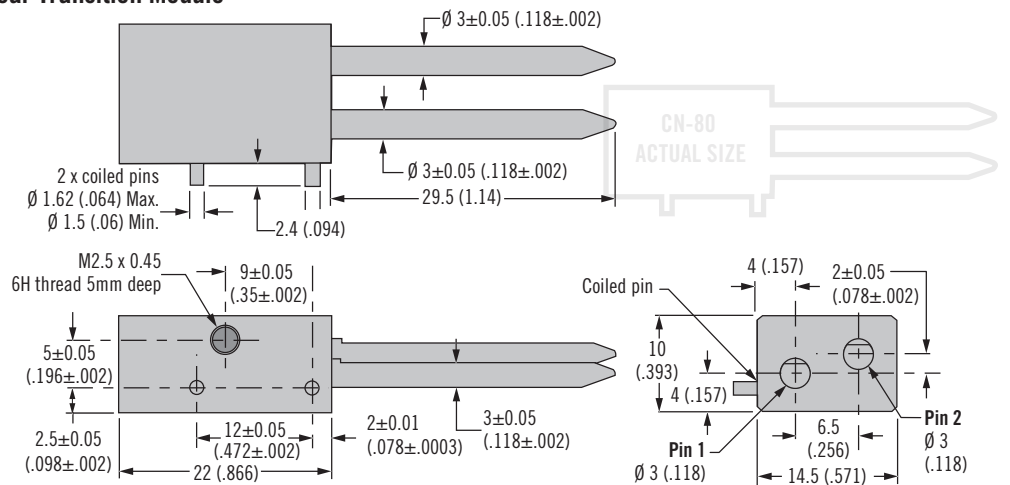

Dual Pin Part Number



- B** Pin length
 68 A1 backplane 22.5 (.885)
 78 A2 midplane 29.5 (1.16)

A2 Rear Transition Module Part Number



	X Pin 1 Position	Rotation	Keying Position
1		0°	
2		45°	
3		90°	
4		135°	
5		180°	
6		225°	
7		270°	
8		315°	

Single Pin - A1 Backplane

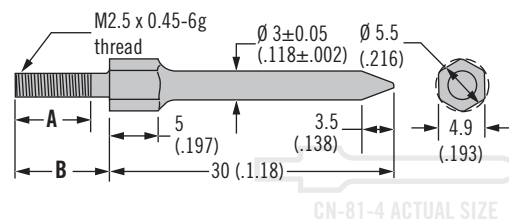

Single Pin Part Number	A	B
CN-81-4	4 (.157)	6 (.236)
CN-81-6	6 (.236)	8 (.315)
CN-81-8	8 (.315)	10 (.394)

CN ATCA® Inject / Eject Mechanism

Alignment receptacle modules

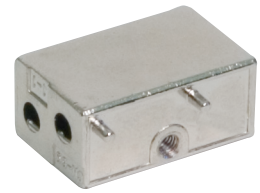

K1 - K2 Front Board

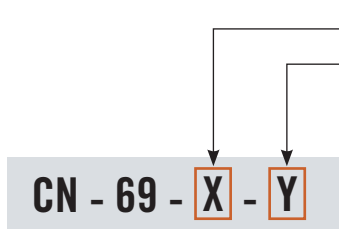
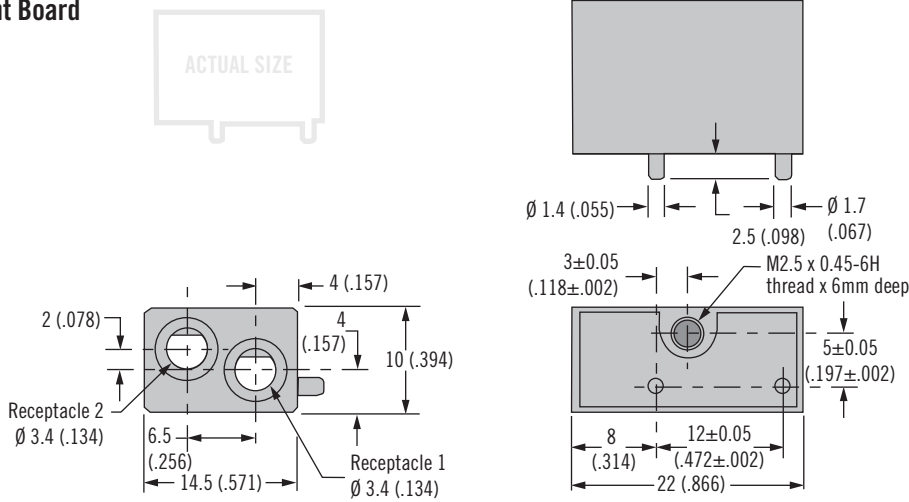

X	Receptacle 1 Position	Rotation	Receptacle Position
Y	Receptacle 2 Position		
1		0°	
2		45°	
3		90°	
4		135°	
5		180°	
6		225°	
7		270°	
8		315°	
9		N/A	
0		N/A	

- Mates with pins

Material and Finish

Zinc alloy, nickel plated

Notes

Receptacle module rotation position must mate with keying module rotation position

ATCA is a registered trademark of PICMG® - PCI Industrial Computer Manufacturers Group, Inc.

rK1 Rear Transition Module

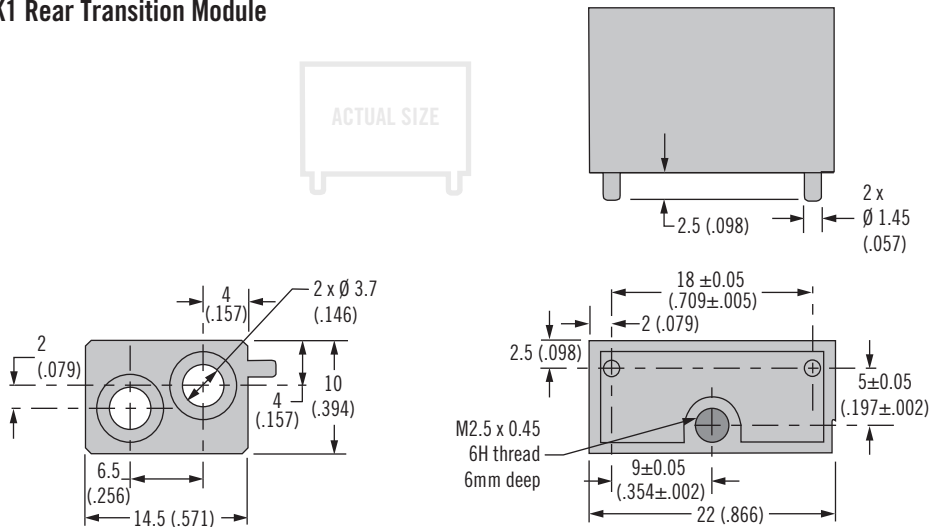

Part Number
CN-79