



# D9 DZUS® Tech Line Quarter-Turn Fasteners

## D9-47 Stud Assemblies · Press-in style

- Designed for hand operation
- Spring ejected
- Wide variety of receptacle options

### Material and Finish

Stud and ferrule: Steel, hardened, zinc plated plus sealer  
 Spring: Music wire, zinc plated  
 Knob: Aluminum, natural or black powder coated

### Installation Notes

1. Prepare panel as shown. Top edge of hole should be sharp.
2. Press stud assembly into panel until ferrule is installed as shown.
3. See page 627 for more installation guidelines.

### Part Number

See table

### Black Knob Option

For black powdered coated knob, add "000" to the part number.

Example:

D9-47-1301-K, natural  
 D9-47-1301-K000, black

### Receptacle Details

See page 471

### Notes

 To ensure you receive **SOUTHCO®** quality parts, look for the segmented circle.

### Press-in Style Stud Assembly

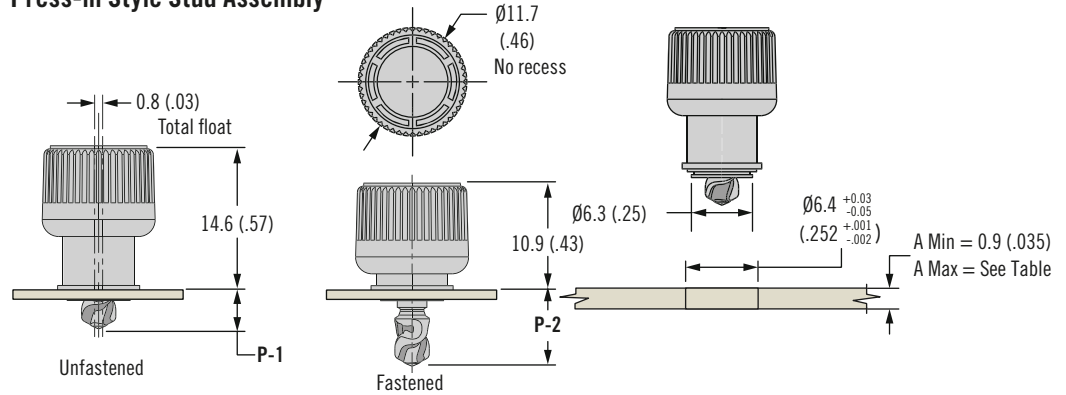

Stud Length Table															
A			B			C			D			Stud Assemblies			
Flat receptacle D9-61-11 mounted below panel			Flat receptacle D9-61-11 mounted above panel			Saddle receptacle D9-62-11			Press-in receptacle D9-63-11						
TMT Range			TMT Range			TMT Range			TMT Range			P-1	P-2	Stud Length	Part Number
Min	Nom-inal	Max	Min	Nom-inal	Max	Min	Nom-inal	Max	Min	Nom-inal	Max				
2.1 (.08)	2.8 (.11)	3.0 (.12)	2.9 (.11)	3.6 (.14)	3.8 (.15)	5.3 (.21)	6.0 (.24)	6.2 (.24)	1.4 (.06)	2.1 (.08)	2.3 (.09)	4.6 (.18)	8.3 (.33)	1	D9-47-1301-K
3.1 (.12)	3.8 (.15)	4.0 (.16)	3.9 (.15)	4.6 (.18)	4.8 (.19)	6.3 (.25)	7.0 (.28)	7.2 (.28)	2.4 (.09)	3.1 (.12)	3.3 (.13)	5.6 (.22)	9.3 (.37)	2	D9-47-1302-K
4.1 (.16)	4.8 (.19)	5.0 (.20)	4.9 (.19)	5.6 (.22)	5.8 (.23)	7.3 (.29)	8.0 (.31)	8.2 (.32)	3.4 (.13)	4.1 (.16)	4.3 (.17)	6.6 (.26)	10.3 (.41)	3	D9-47-1303-K
5.1 (.20)	5.8 (.23)	6.0 (.24)	5.9 (.23)	6.6 (.26)	6.8 (.27)	8.3 (.33)	9.0 (.35)	9.2 (.36)	4.4 (.17)	5.1 (.20)	5.3 (.21)	7.6 (.30)	11.3 (.44)	4	D9-47-1304-K

Receptacle Types (Stud Assembly shown fastened for P-2 = 8.75 (.34) all views)  
 Q = 0.9 (.035) MIN Frame (all receptacle views)

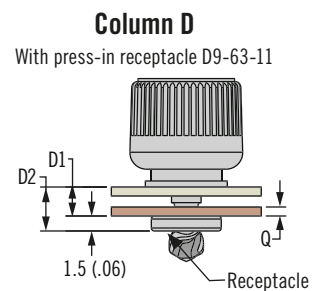
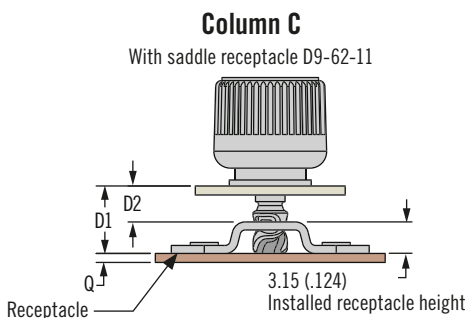
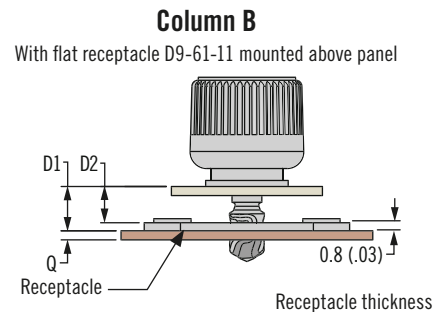
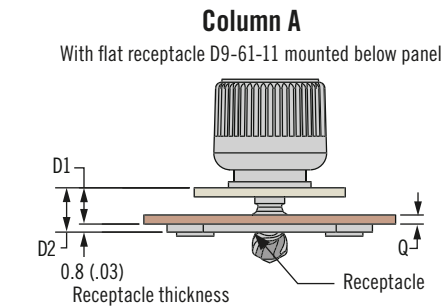

Dimensions in millimeters (inch) unless otherwise stated

# D9 DZUS® Tech Line Quarter-Turn Fasteners

## D9-47 Stud Assemblies · Flare-in style



### Flare-in Style Stud Assembly

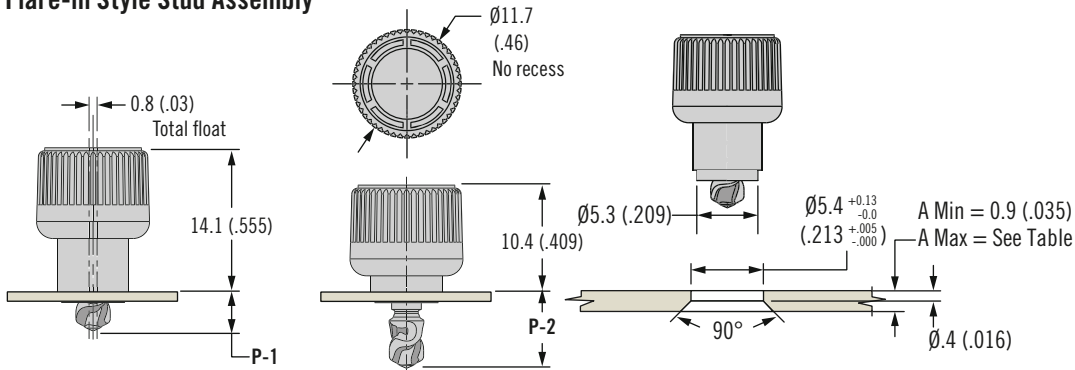

Stud Length Table															
A			B			C			D			Stud Assemblies			
Flat receptacle D9-61-11 mounted below panel			Flat receptacle D9-61-11 mounted above panel			Saddle receptacle D9-62-11			Press-in receptacle D9-63-11						
TMT Range			TMT Range			TMT Range			TMT Range			P-1	P-2	Stud Length	Part Number
Min	Nom-inal	Max	Min	Nom-inal	Max	Min	Nom-inal	Max	Min	Nom-inal	Max				
2.1 (.08)	2.8 (.11)	3.0 (.12)	2.9 (.11)	3.6 (.14)	3.8 (.15)	5.3 (.21)	6.0 (.24)	6.2 (.24)	1.4 (.06)	2.1 (.08)	2.3 (.09)	4.6 (.18)	8.3 (.33)	1	D9-47-3301-K
3.1 (.12)	3.8 (.15)	4.0 (.16)	3.9 (.15)	4.6 (.18)	4.8 (.19)	6.3 (.25)	7.0 (.28)	7.2 (.28)	2.4 (.09)	3.1 (.12)	3.3 (.13)	5.6 (.22)	9.3 (.37)	2	D9-47-3302-K
4.1 (.16)	4.8 (.19)	5.0 (.20)	4.9 (.19)	5.6 (.22)	5.8 (.23)	7.3 (.29)	8.0 (.31)	8.2 (.32)	3.4 (.13)	4.1 (.16)	4.3 (.17)	6.6 (.26)	10.3 (.41)	3	D9-47-3303-K
5.1 (.20)	5.8 (.23)	6.0 (.24)	5.9 (.23)	6.6 (.26)	6.8 (.27)	8.3 (.33)	9.0 (.35)	9.2 (.36)	4.4 (.17)	5.1 (.20)	5.3 (.21)	7.6 (.30)	11.3 (.44)	4	D9-47-3304-K

Receptacle Types (Stud Assembly shown fastened for P-2 = 9.3 (.366) all views)  
 Q = 0.9 (.035) MIN Frame (all receptacle views)

#### Column A

With flat receptacle D9-61-11 mounted below panel

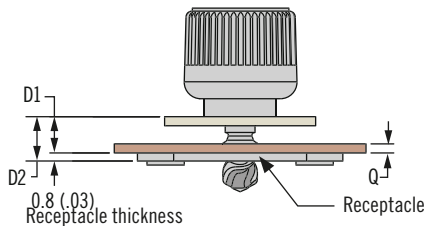

#### Column B

With flat receptacle D9-61-11 mounted above panel

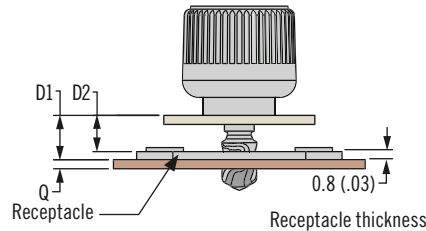

#### Column C

With saddle receptacle D9-62-11

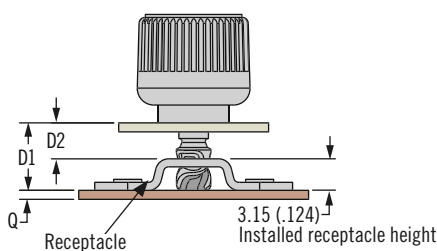

#### Column D

With press-in receptacle D9-63-11

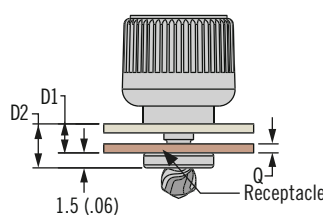

- Designed for hand operation
- Spring ejected
- Wide variety of receptacle options

### Material and Finish

Stud: Steel, hardened, zinc plated plus sealer  
 Spring: Music wire, zinc plated  
 Knob: Aluminum, natural or black powder coated  
 Ferrule: Aluminum, natural

### Installation Notes

1. Drill then counter-sink panel as shown.
2. Insert stud assembly into prepared hole in panel and flare stand-off using tool 47-106. Use LIGHT pressure

### Part Number

See table

### Black Knob Option

For black powdered coated knob, add "000" to the part number.

Example:

D9-47-3301-K, natural  
 D9-47-3301-K000, black

### Receptacle Details

See page 471

### Notes

 To ensure you receive SOUTHCO® quality parts, look for the segmented circle.



# D9 DZUS® Tech Line Quarter-Turn Fasteners

## D9-47 Stud Assemblies · Surface Mount Technology (SMT) style

- Designed for hand operation
- Spring ejected
- Wide variety of receptacle options

### Material and Finish

Stud: Steel, hardened, zinc plated plus sealer  
 Spring: Music wire, zinc plated  
 Knob: Aluminum, natural or black powder coated  
 Retainer (not shown): Plastic  
 Ferrule: Steel, tin plated

### Installation Notes

Visit [www.southco.com](http://www.southco.com) for additional installation guidelines

### Part Number

See table

### Black Knob Option

For black powdered coated knob, add "000" to the part number.

Example:

D9-47-2301-K-R, natural

D9-47-2301-K000-R, black

### Specify Package Option

Package Details

Stud Assemblies shipped

in Reel Package

### Receptacle Details

See page 471

### Notes

 To ensure you receive **SOUTHCO®** quality parts, look for the segmented circle.

### SMT Style Stud Assembly

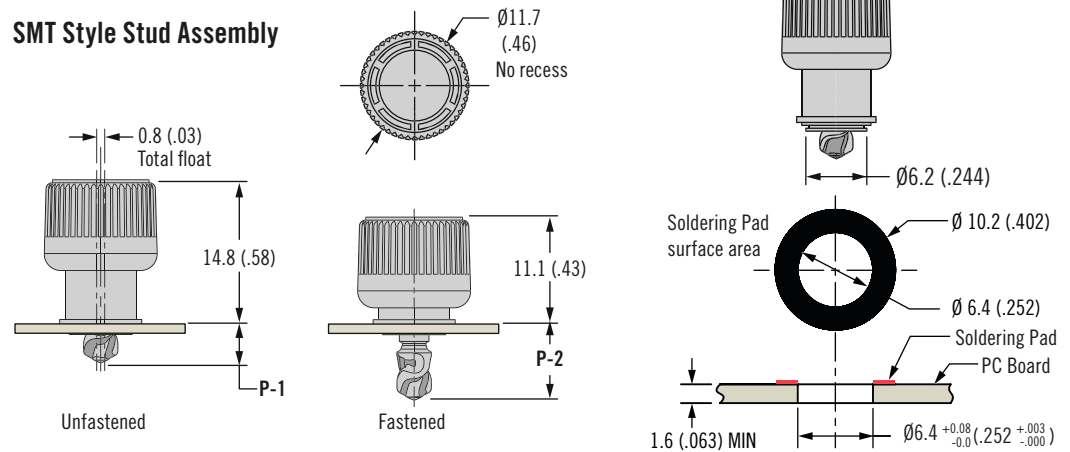

Stud Length Table															
A			B			C			D			Stud Assemblies			
Flat receptacle D9-61-11 mounted below panel			Flat receptacle D9-61-11 mounted above panel			Saddle receptacle D9-62-11			Press-in receptacle D9-63-11						
TMT Range			TMT Range			TMT Range			TMT Range						
Min	Nom-inal	Max	Min	Nom-inal	Max	Min	Nom-inal	Max	Min	Nom-inal	Max	P-1	P-2	Stud Length	Part Number
Stud length not viable			2.2 (.09)	2.9 (.11)	3.1 (.12)	4.55 (.18)	5.25 (.21)	5.45 (.21)	Stud length not viable			3.8 (.15)	7.45 (.29)	1	D9-47-2301-K-R
2.4 (.09)	3.1 (.12)	3.3 (.13)	3.2 (.13)	3.9 (.15)	4.1 (.16)	5.55 (.22)	6.25 (.25)	6.45 (.25)	Stud length not viable			4.8 (.19)	8.45 (.33)	2	D9-47-2302-K-R
3.4 (.13)	4.1 (.16)	4.3 (.17)	4.2 (.17)	4.9 (.19)	5.1 (.20)	6.55 (.26)	7.25 (.29)	7.45 (.29)	1.8 (.07)	2.5 (.10)	2.7 (.11)	5.8 (.23)	9.45 (.37)	3	D9-47-2303-K-R
4.4 (.17)	5.1 (.20)	5.3 (.21)	5.2 (.20)	5.9 (.23)	6.1 (.24)	7.55 (.30)	8.25 (.32)	8.45 (.33)	2.8 (.11)	3.5 (.14)	3.7 (.15)	6.8 (.27)	10.45 (.41)	4	D9-47-2304-K-R

Receptacle Types (Stud Assembly shown fastened for P-2 = 8.45 (.333) all views)

Q = 0.9 (.035) MIN Frame (all receptacle views)

### Column A

With flat receptacle D9-61-11 mounted below panel

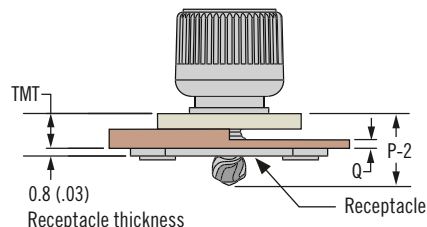

### Column B

With flat receptacle D9-61-11 mounted above panel

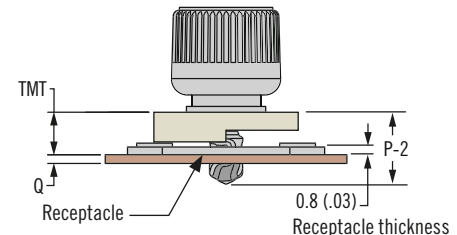

### Column C

With saddle receptacle D9-62-11

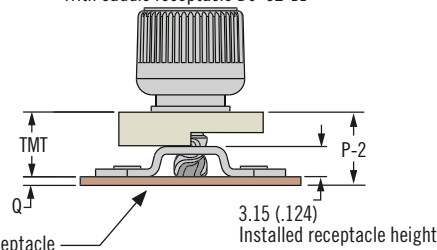

### Column D

With press-in receptacle D9-63-11

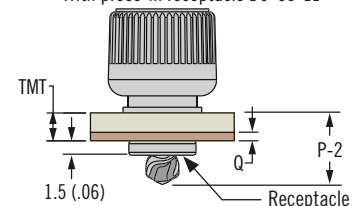

Dimensions in millimeters (inch) unless otherwise stated

# D9 DZUS® Tech Line Quarter-Turn Fasteners Receptacles



## Flat Type Receptacle

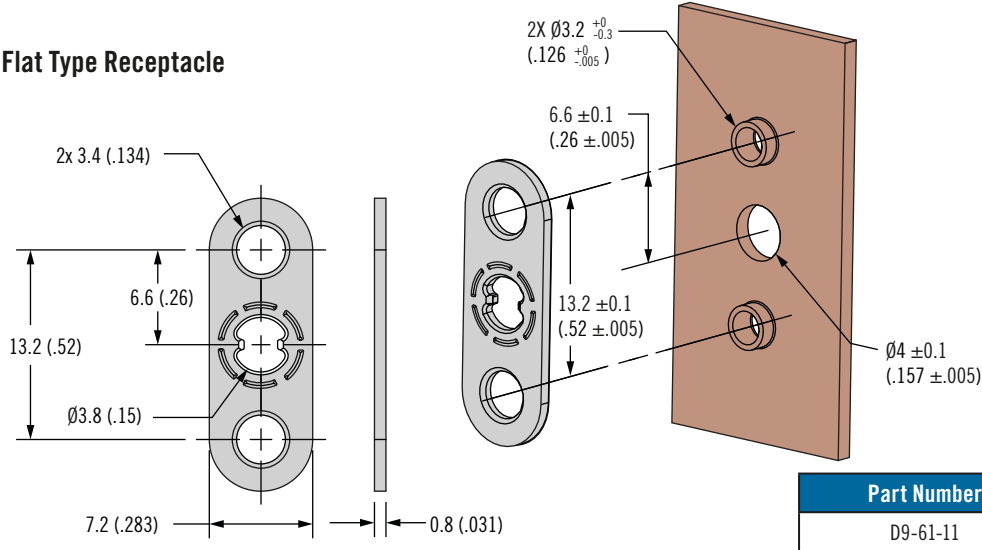

Part Number
D9-61-11

### Material and Finish

Steel, zinc plate

Suitable for use with all assembly styles and stud lengths

### Part Number

See table

## Saddle Type Receptacle

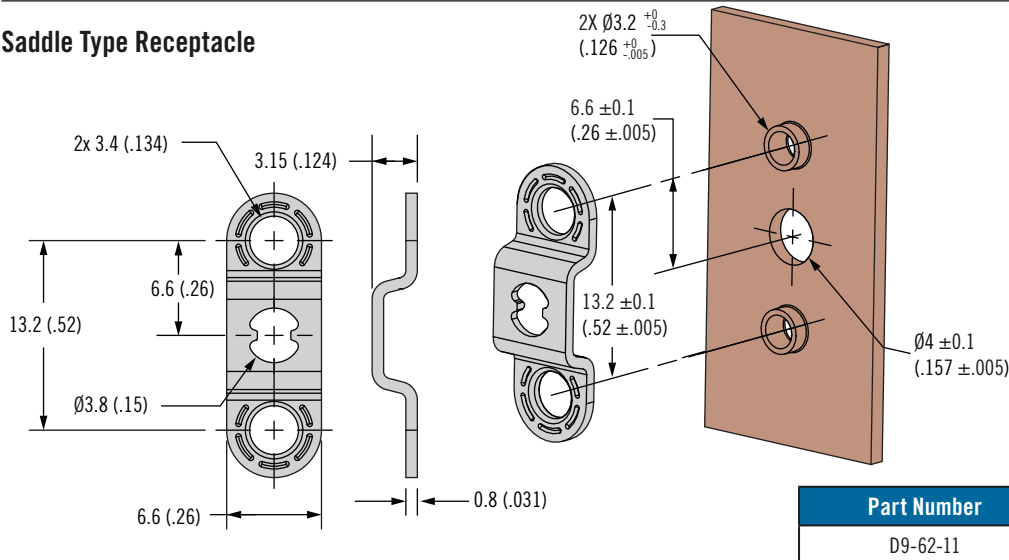

Part Number
D9-62-11

### Material and Finish

Steel, zinc plate

Suitable for use with all assembly styles and stud lengths

### Part Number

See table

## Self-Clinching Type Receptacle

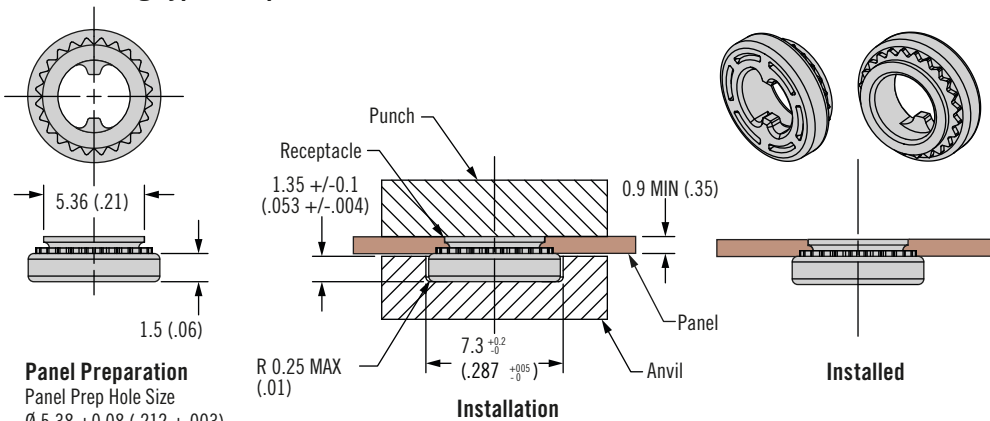

**Panel Preparation**  
Panel Prep Hole Size  
Ø 5.38 ± 0.08 (.212 ± .003)

Part Number
D9-63-11

### Material and Finish

Steel, zinc plate plus sealer

### Installation Notes

1. Drill or punch panel prep hole.
  2. Place receptacle into anvil and put panel over lip of receptacle
  3. While keeping punch and anvil parallel, apply force until shoulder of receptacle contacts panel.
- Recommended load of 13,400 N (3000 lbf) for steel, Rb 70 max, 11,200 N (2500 lbf) for aluminum

### Part Number

See table



# D9 DZUS® Tech Line Quarter-Turn Fasteners

## D9-52 Stud Assemblies · Press-in style

- Designed for hand or tool operation
- Spring ejected
- Wide variety of receptacle options
- Designate access points with color

### Material and Finish

Stud: Hardened carbon steel, zinc plated, chromate, plus sealer  
 Spring: Music wire, zinc plated  
 Standoff: Carbon steel, zinc plated, chromate, plus sealer  
 Prism: PC/ABS

### Press-in Style Stud Assembly

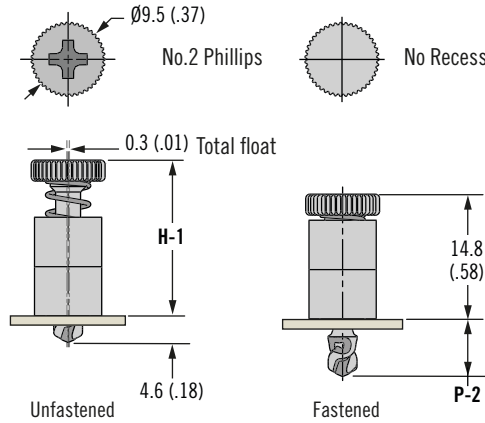

### Installation

Bright or Prism

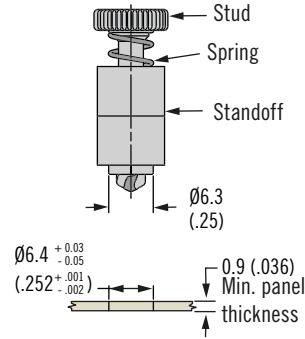

**000** Black ●

**008** Blue ●

**013** Red ●

**014** Green ●

**Your color** (contact Southco) ●

Stud Length Table																	
A			B			C			D			Stud Assemblies					
Flat receptacle D9-61-11 mounted below panel			Flat receptacle D9-61-11 mounted above panel			Saddle receptacle D9-62-11			Press-in receptacle D9-63-11			Part Number, Press-in					
TMT Range			TMT Range			TMT Range			TMT Range			P-2	H-1	Bright Head		Prism Head	
Min	Nomi-nal	Max	Min	Nomi-nal	Max	Min	Nomi-nal	Max	Min	Nomi-nal	Max			No Recess	Phillips Recess	No Recess	Phillips Recess
2.1 (.08)	2.8 (.11)	3.0 (.12)	2.9 (.11)	3.6 (.14)	3.8 (.15)	5.3 (.21)	6.0 (.24)	6.2 (.24)	1.4 (.06)	2.1 (.08)	2.3 (.09)	8.3 (.33)	18.5 (.73)	D9-52-1301-K	D9-52-1311-K	D9-52-1301-K000	D9-52-1311-K000
3.1 (.12)	3.8 (.15)	4.0 (.16)	3.9 (.15)	4.6 (.18)	4.8 (.19)	6.3 (.25)	7.0 (.28)	7.2 (.28)	2.4 (.09)	3.1 (.12)	3.3 (.13)	9.3 (.37)	19.5 (.77)	D9-52-1302-K	D9-52-1312-K	D9-52-1302-K000	D9-52-1312-K000
4.1 (.16)	4.8 (.19)	5.0 (.20)	4.9 (.19)	5.6 (.22)	5.8 (.23)	7.3 (.29)	8.0 (.31)	8.2 (.32)	3.4 (.13)	4.1 (.16)	4.3 (.17)	10.3 (.41)	20.5 (.81)	D9-52-1303-K	D9-52-1313-K	D9-52-1303-K000	D9-52-1313-K000
5.1 (.20)	5.8 (.23)	6.0 (.24)	5.9 (.23)	6.6 (.26)	6.8 (.27)	8.3 (.33)	9.0 (.35)	9.2 (.36)	4.4 (.17)	5.1 (.20)	5.3 (.21)	11.3 (.44)	21.5 (.85)	D9-52-1304-K	D9-52-1314-K	D9-52-1304-K000	D9-52-1314-K000

Q=0.9 (.035) MIN Frame Thickness (All receptacle views)

### Installation notes:

1. Prepare panel as shown. Top edge of hole should be sharp.
2. Press stud assembly into panel until Standoff is installed as shown.
3. See page 627 for more installation guidelines.

### Specifying Prism Color:

To indicate color, change the last three digits of the part number. Example D9-52-1301-K000, black, D9-52-1301-K013, red Receptacle Details See page 471

### Column A

Flat receptacle D9-61-11 mounted below panel

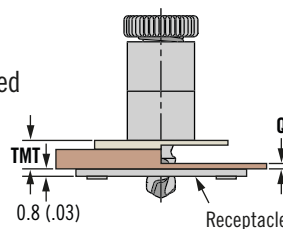

### Column B

Flat receptacle D9-61-11 mounted above panel

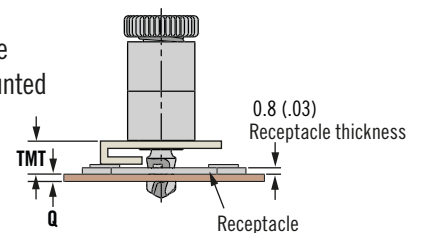

### Column C

Saddle receptacle D9-62-11

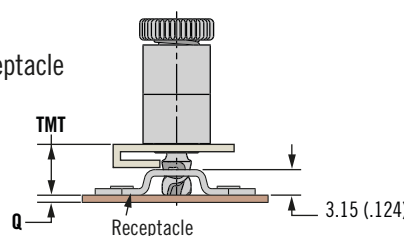

### Column D

Press-in receptacle D9-63-11

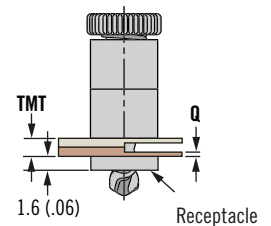

# D9 DZUS® Tech Line Quarter-Turn Fasteners

## D9-52 Stud Assemblies · Flare-in Style



### Flare-in Style Stud Assembly

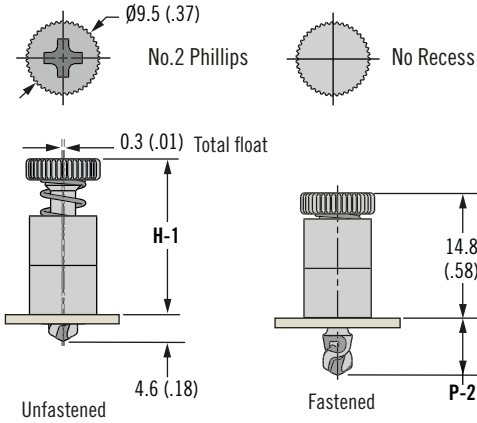

### Installation

Bright or Prism

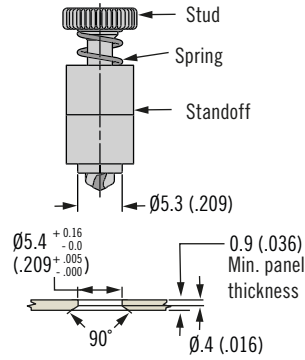

- 000** Black
- 008** Blue
- 013** Red
- 014** Green
- Your color** (contact Southco)

- Designed for hand or tool operation
- Spring ejected
- Wide variety of receptacle options
- Designate access points with color

### Material and Finish

Stud: Steel, hardened, zinc plated plus sealer  
 Spring: Music wire, zinc plated  
 Standoff: Aluminum, natural  
 Prism: PC/ABS

Stud Length Table

A			B			C			D			Stud Assemblies					
Flat receptacle D9-61-11 mounted below panel			Flat receptacle D9-61-11 mounted above panel			Saddle receptacle D9-62-11			Press-in receptacle D9-63-11			Part Number, Press-in					
TMT Range			TMT Range			TMT Range			TMT Range			P-2	H-1	Bright Head		Prism Head	
Min	Nominal	Max	Min	Nominal	Max	Min	Nominal	Max	Min	Nominal	Max			No Recess	Phillips Recess	No Recess	Phillips Recess
2.1 (.08)	2.8 (.11)	3.0 (.12)	2.9 (.11)	3.6 (.14)	3.8 (.15)	5.3 (.21)	6.0 (.24)	6.2 (.24)	1.4 (.06)	2.1 (.08)	2.3 (.09)	8.3 (.33)	18.5 (.73)	D9-52-3301-K	D9-52-3311-K	D9-52-3301-K000	D9-52-3311-K000
3.1 (.12)	3.8 (.15)	4.0 (.16)	3.9 (.15)	4.6 (.18)	4.8 (.19)	6.3 (.25)	7.0 (.28)	7.2 (.28)	2.4 (.09)	3.1 (.12)	3.3 (.13)	9.3 (.37)	19.5 (.77)	D9-52-3302-K	D9-52-3312-K	D9-52-3302-K000	D9-52-3312-K000
4.1 (.16)	4.8 (.19)	5.0 (.20)	4.9 (.19)	5.6 (.22)	5.8 (.23)	7.3 (.29)	8.0 (.31)	8.2 (.32)	3.4 (.13)	4.1 (.16)	4.3 (.17)	10.3 (.41)	20.5 (.81)	D9-52-3303-K	D9-52-3333-K	D9-52-3303-K000	D9-52-3333-K000
5.1 (.20)	5.8 (.23)	6.0 (.24)	5.9 (.23)	6.6 (.26)	6.8 (.27)	8.3 (.33)	9.0 (.35)	9.2 (.36)	4.4 (.17)	5.1 (.20)	5.3 (.21)	11.3 (.44)	21.5 (.85)	D9-52-3304-K	D9-52-3314-K	D9-52-3304-K000	D9-52-3314-K000

Q=0.9 (.035) MIN Frame Thickness (All receptacle views)

**Column A**  
 Flat receptacle  
 D9-61-11 mounted  
 below panel

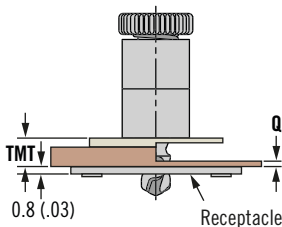

**Column B**  
 Flat receptacle  
 D9-61-11 mounted  
 above panel

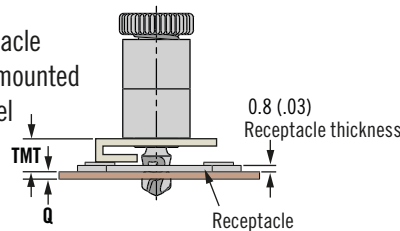

**Column C**  
 Saddle receptacle  
 D9-62-11

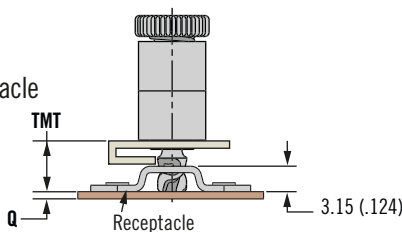

**Column D**  
 Press-in receptacle  
 D9-63-11

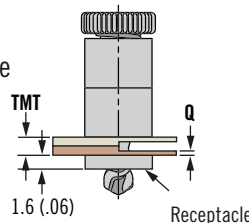

### Installation notes:

1. Drill then counter-sink panel as shown.
2. Insert stud assembly into prepared hole in panel and flare stand-off using tool 47-106. Use LIGHT pressure

### Specifying Prism Color:

To indicate color, change the last three digits of the part number. Example D9-52-1311-K000, black, D9-52-1311-K013, red  
 Receptacle Details See page 471



# D9 - *DZUS*<sup>®</sup> Tech Line Quick Access Fasteners

## D9-PR PCI Riser Cage Fastener Assembly

- Designed for 2U Servers
- Hand operation
- Spring ejected
- Wide variety of receptacle options

### Fastener Assembly Material and Finish

Cap: UL94-V0 PA6  
 Assembly Cover: PC-ABS, black  
 Pin, Washer: Stainless steel,  
 passivate Lower Stud, Bracket, Clip:  
 Steel, zinc plate Rotation Limiter,  
 Upper Stud: Zinc alloy, chromate  
 sealer

### Installation Notes

Maximum installation torque  
 of mounting screws to attach  
 assembly covers  
 0.7 Nm (6 in-lbs) using M3 screws.

### Performance Details

Maximum torque to be applied to  
 cap is 1.1 Nm (10 in-lbs)

### Part Numbers

See tables

### Receptacle Details

(order separately)

See page 471

Fastener Assembly

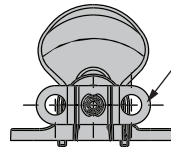
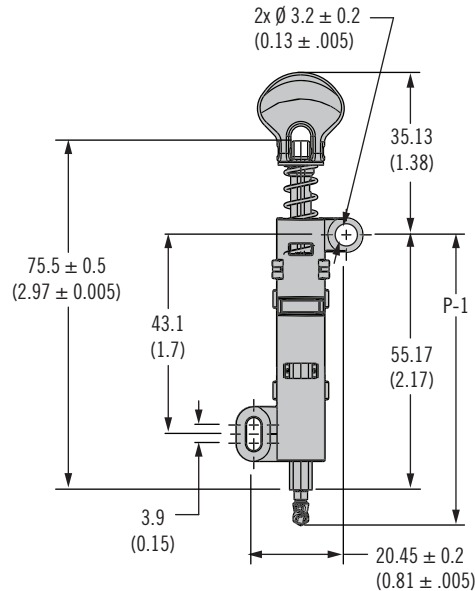
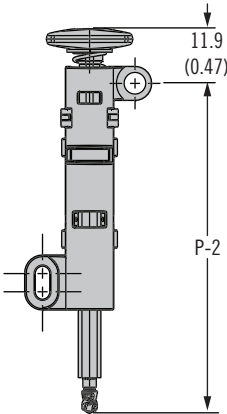
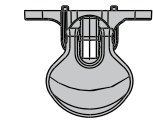

Fastened

Please note  
 correct receptacle  
 Orientation

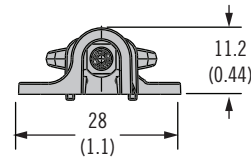

Unfastened

To fasten, push on cap to place lower stud into receptacle and turn cap 180° and fold down.

Part Number	TMT	P-1	P-2	Cap Color
D9-PR-20-000	4.25	62.4 ± 1.2 (2.45 ± 0.04)	70.9 ± 1.2 (2.78 ± 0.04)	Black
D9-PR-20-072	(0.16)			Blue
D9-PR-21-000	4.45	62.6 ± 1.2 (2.46 ± 0.04)	71.1 ± 1.2 (2.79 ± 0.04)	Black
D9-PR-21-072	(0.17)			Blue
D9-PR-22-000	4.65	62.8 ± 1.2 (2.47 ± 0.04)	71.3 ± 1.2 (2.80 ± 0.04)	Black
D9-PR-22-072	(0.18)			Blue

TMT = Customer panel thickness + Customer PCB thickness + Southco receptacle thickness + Southco gasket compressed thickness (0.55 mm)

### Gasket

Part Number	Material	Color
D9-81 (order separately)	High density foam	Gray

# D9 - *DZUS*<sup>®</sup> Tech Line Quick Access Fasteners

## D9-PR PCI Riser Cage Fastener Assembly



473B

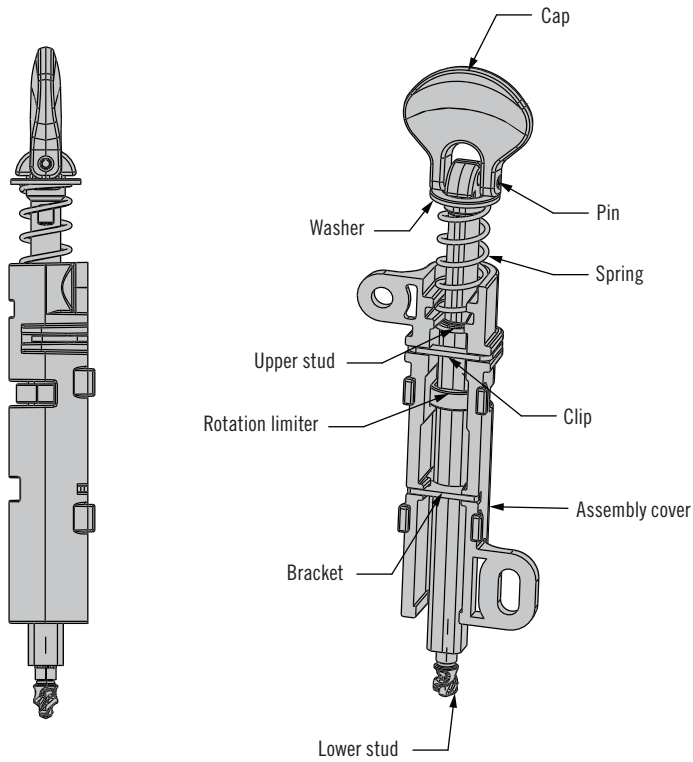

### Panel Preparation

