

CABIN & COCKPIT ENTRY HARDWARE

MC Compact Cabin Door Lock

A



DOOR THICKNESS RANGE: 19 - 32mm (3/4" - 1-1/4")

The Compact features a simple yet graceful design that works with all swing-door variations. The Compact is designed for Cabin, Stateroom, and Head-door applications.

- All marine-grade materials, including stainless steel and brass for superior corrosion resistance
- Emergency lock override
- Easy installation with rounded forends
- One part number for all swing-door variations

Available Options:

- Finish: Options include: Chrome with/without Brass accent, Satin
- Escutcheon Plates: "Long Island"
- Operation: Universal design fits all door swings
- Accessories
- Doorkeeper: Used to hold door open

For strikers
see page 23

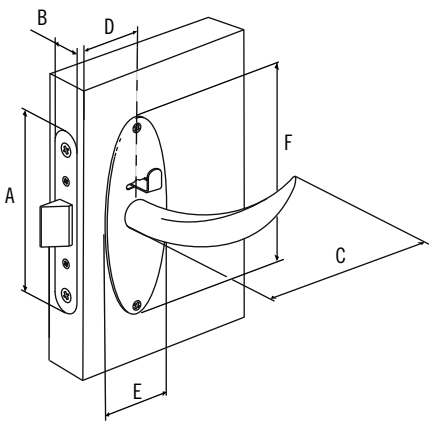
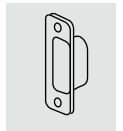

F = Long Island

	Imperial		Metric
	Nominal	Decimal	
A	3 9/16	3.55	90
B	5/8	.63	16
C	3 5/16	3.31	84
D	1 1/4	1.26	32
E	1 3/8	1.38	35
F	3 13/16	3.82	97

Panel Preparation

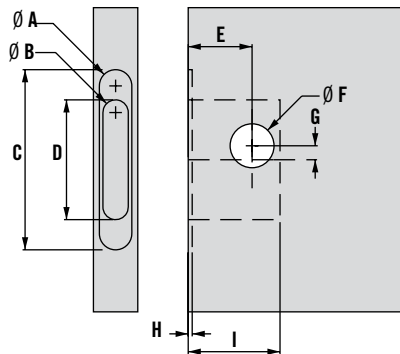

	Compact Long Island		
	Imperial		Metric
	Nominal	Decimal	
A	5/8	.64	16
B	1/2	.50	13
C	3 9/16	3.553	90
D	2 3/8	2.362	60
E	1 17/64	1.26	32
F	7/8	.866	22
G	9/32	.276	7
H	5/64	.079	2
I	1 13/16	1.811	46

How to override a locked Compact door lock from the outside

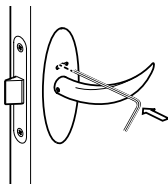

For installation details see opposite page.

COMPACT PART NUMBERS						
Escutcheon Plate Finish	Privacy	Out	In	Left	Right	
Long Island, chrome	X	X	X	X	X	MC-01-120-10
Long Island, chrome, brass accent	X	X	X	X	X	MC-01-120-14
Long Island, satin	X	X	X	X	X	MC-01-120-20
Long Island, cast chrome,	X	X	X	X	X	MC-02-120-10



CABIN & COCKPIT ENTRY HARDWARE Doorkeeper

The Doorkeeper stops and holds doors open. They are designed to work with the McCoy, Offshore and Compact latches (see pages 12-15 and opposite).

- All Marine-grade ABS materials
- Damping/non-vibration feature keeps doors from rattling when held open
- Easy to install

Available Options:

- Color: Available in black or white.

	Imperial		Metric
	Nominal	Decimal	
A	13/16	.787	20
B	1 7/8	1.898	48
C Offshore	1 15/16	1.913	49
C Compact	2 3/16	2.189	56

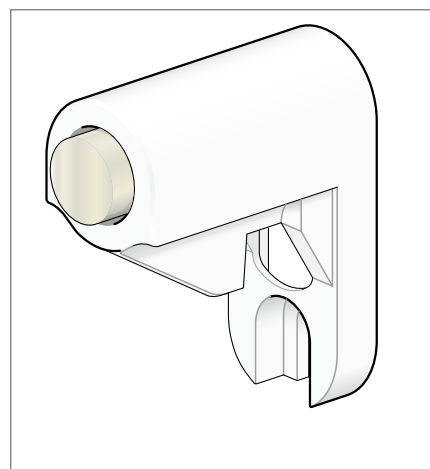
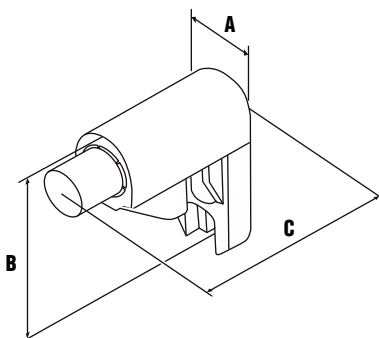

A

Operation

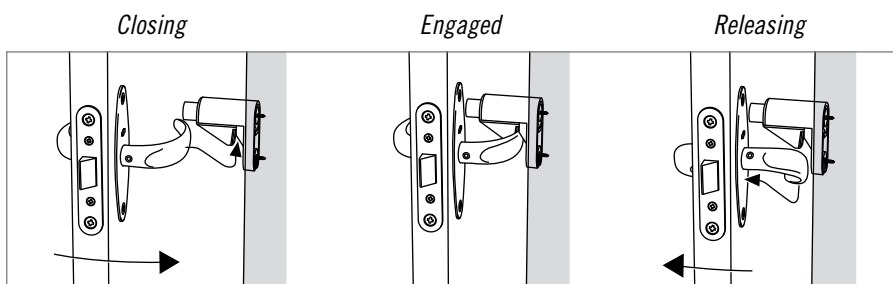

DOORKEEPER PART NUMBERS	
Offshore, Black	MC-91-102-50
Offshore, White	MC-91-102-70
Compact, Black	MC-91-101-50
Compact, White	MC-91-101-70

MC Compact Installation

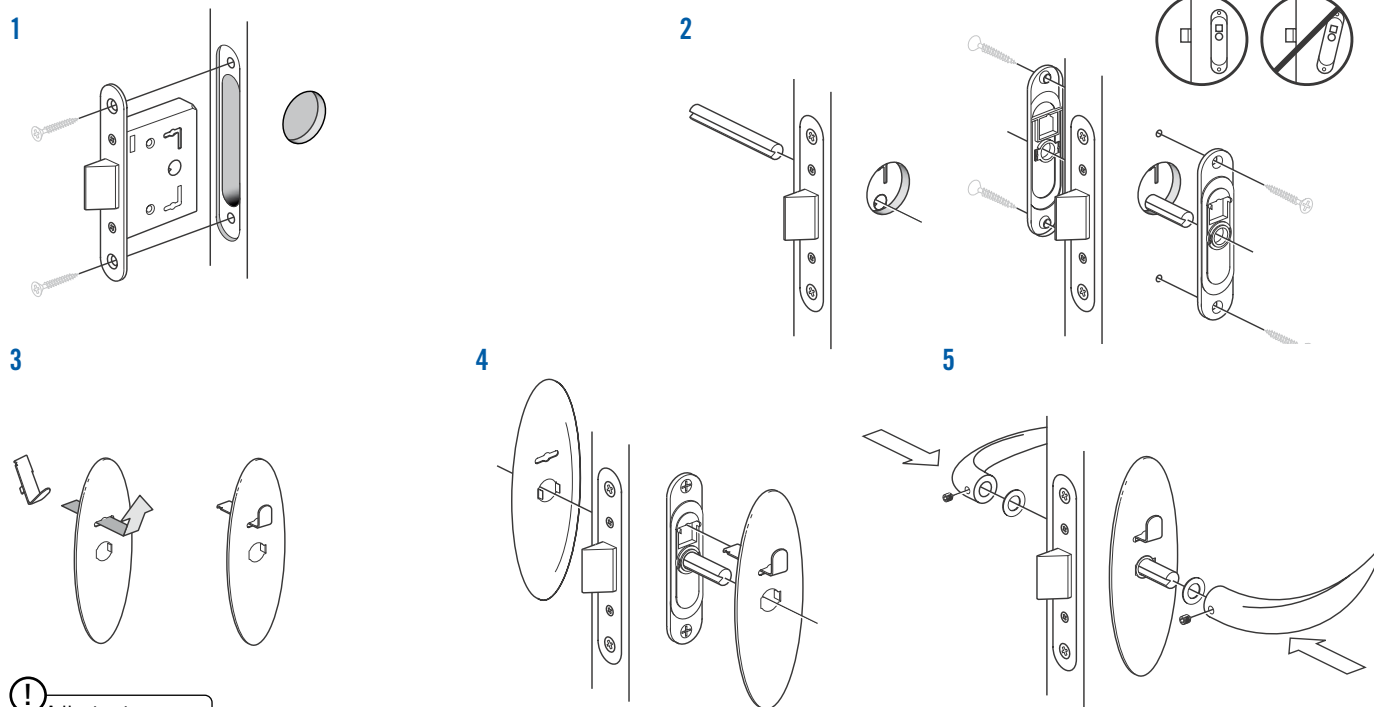

! Adjust set screw to secure handle



MC Striker

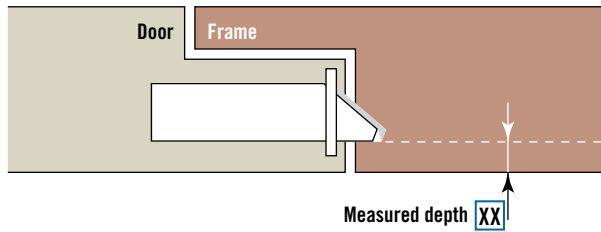
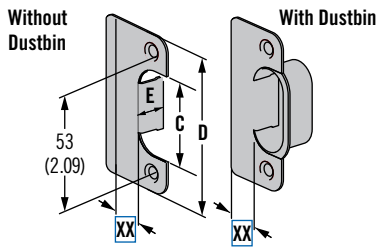

To find the right striker for your application, measure the distance from the door face to the edge of the springbolt of the latch.

C		D		E	
Metric	Imperial	Metric	Imperial	Metric	Imperial
36	1 7/16	68	2 11/16	13	1/2

Part Number Selection

MC - 90 - Z XX - FF

Z Dustbin Option
 1 No Dustbin
 2 With Dustbin

XX Position
 03 3mm (7/64") 13 13mm (1/2")
 05 5mm (3/16") 16 16mm (5/8")
 07 7mm (1/4") 21 21mm (7/8")
 09 9mm (3/8")

FF Finish
 10 Brass, nickel plated
 24 Stainless steel

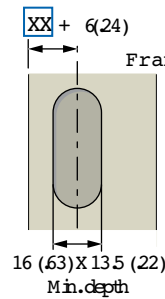

www.southco.com/MC



MC Whale Striker

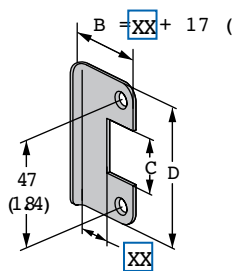

C		D	
Metric	Imperial	Metric	Imperial
60	2 3/8	22	7/8

Part Number Selection

MC - 90 - 3 - XX - FF

XX Position
 03 3mm (7/64") 13 13mm (1/2")
 05 5mm (3/16") 16 16mm (5/8")
 07 7mm (1/4") 21 21mm (7/8")
 09 9mm (3/8")

FF Finish
 10 Brass, nickel plated
 40 Brass

- Suitable for Offshore, McCoy and Compact swing door latches.
- Quick and easy installation

Other options available. For complete details on variety, part numbers, installation and specification, go to



www.southco.com/MC